

# COMMANDER WAREHOUSE EQUIPMENT LTD.

**QUALITY** MATERIAL  
HANDLING AND  
STORAGE PRODUCTS



## VANCOUVER

119-930 West 1st Street  
North Vancouver, BC, V7P 3N4  
P: (604) 980-8511  
TF: 1 (800) 605-4822

## SURREY

5225 192 Street,  
Surrey, BC, V3S 8E5  
P: (604) 574-5797  
TF: 1 (800) 796-8010

## CALGARY

102-1437 47 Ave NE,  
Calgary, AB, T2E 6N7  
P: (403) 291-3223  
TF: 1 (800) 605-4847

## EDMONTON

3604 74 Ave NW,  
Edmonton, AB, T6B 2P7  
P: (780) 468-4395  
TF: 1 (800) 580-1089

## TABLE OF CONTENTS

Racking Systems	04-05
Shelving Systems	06-08
High-Density Storage	09-11
Rolling Products	12-19
Bins & Containers	20-25
Cabinets & Lockers	26-28
Work Centers	29-31
Security Enclosures	32
Mezzanines	33-34
Pallet Trucks and Lifting Equipment	34-35
Dock Equipment	35-37
Rubber Matting	38

Commander Warehouse Equipment Ltd. works hard to provide customers with a more complete product line that features products from Canadian suppliers and manufacturers. All of our premium high-quality products are designed to create optimal solutions for any storage or material handling you need.

Visit us at:

[COMMANDER.CA](http://COMMANDER.CA)

PROVIDING SUPERIOR  
**WAREHOUSE  
& STORAGE  
EQUIPMENT**  
ACROSS WESTERN CANADA.



INSTALLATION  
SERVICES



LEASING  
SERVICES



DESIGN  
SERVICES



IN-HOUSE  
MANUFACTURING  
SERVICES

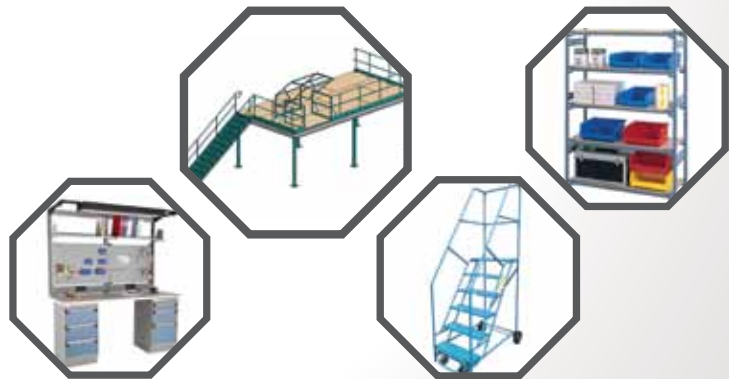



OUR **EXPERTISE**  
COMES FROM 48+  
YEARS OF **EXPERIENCE.**



## 1 SELECTIVE PALLET RACKING

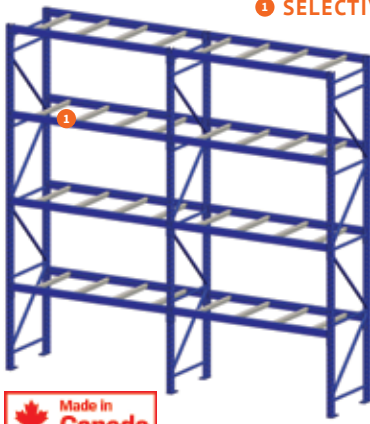

Selective pallet racking is constructed from two basic parts – upright frames and load beams. All beams fit upright to create a flush top level and can be adjusted in height every 3" of the upright without interfering with the beams in the next bay. This type of pallet racking is perfect for storing full pallets or for hand-stocking heavy products on wire decking.

### Upright Frames:

To determine frame height required, add the height of the load including pallet, plus beam height, plus 6" of clearance. Multiply sum by number of levels.

### Adjustable Load Beams:

Choose beam lengths and capacities to suit the width and weight of your pallets. To determine lengths, allow 4" clearance between pallets and 3" between pallets and uprights.

Stock Number	Depth	Height	Capacity Lbs.
894/42-096NAS	42"	8'	22,570
894/42-144NAS	42"	12'	22,570
894/42-192NAS	42"	16'	22,570
894/42-192NAS-HD	42"	16'	33,230

Stock Number	Beam Height	Beam Type	Clear Span Between Upright	Capacity Per Pair (Lbs.)
894/04-096NAS	4"	Box Beam	96" (8')	6,310
894/S4-096NAS	4"	Step Beam	96" (8')	5,470
894/06-096NAS	6"	Box Beam	96" (8')	12,000
894/04-108NAS	4"	Box Beam	108" (9')	5,480
894/S4.5-108NAS	4.5"	Step Beam	108" (9')	5,750
894/06-108NAS	6"	Box Beam	108" (9')	10,980
894/06-144NAS	6"	Box Beam	144" (12')	8,230

## 2 CANTILEVER RACKING



• Ideal for storage of lumber, steel channels, pipes, tubes, plywood and steel plates and items of long length or irregular shape

Cantilever racking is constructed from high tensile structural steel components for added strength and better protection from damage, abuse, or impact in even the harshest warehouse environment.

This type of racking system is specifically designed to handle a wide variety of products, especially long and irregular shaped products, by providing unrestricted front access for lift truck forks. Cantilever racking systems provide flat or tapered arms for easy loading, with columns acting as backstops for products. All cantilever racking systems feature base legs for stability and to keep products off the floor, as well as bolted arms that are designed to bolt on one or both sides of the column, providing easy conversion from single to double-sided units. The bolted arms for this product are adjustable on 4" centres and are available in a variety of styles and capacities.

Stock Number	Dimensions
<b>Columns</b>	
4308	96" High
4312	144" High
<b>Bases</b>	
4356	48" Long
<b>Arms</b>	
4707	48" Long
<b>Vertical Braces</b>	
4557	60" Wide C/C

# INDUSTRY STANDARD RACKING SYSTEMS

Drive-In Rack

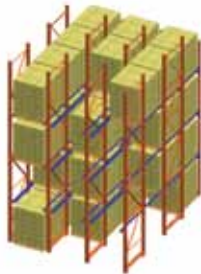

Double Deep Rack

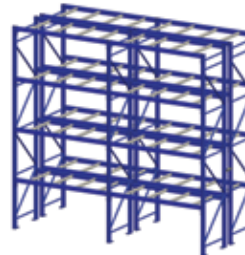

Outdoor Rack



Pick Towers



Push Back Rack

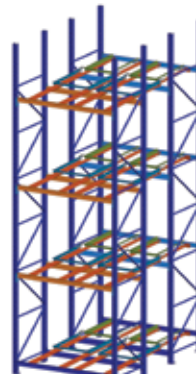

Carton Flow Rack



Pallet Flow Rack





### 3 WIRE MESH DECKS

**Versatility** – store varying sized pallets, boxes, drums.

**Installation is Easy** – Wire Mesh Decks simply drop over your standard pallet rack beams.

**Lighting** – The open wire design allows for light to pass through to lower levels.

**Clean** – Wire Mesh Decks are “self cleaning” as they do not allow for the collection of dust or debris.

Wire mesh decks are made from an all welded construction that provides added strength and versatility to any pallet racking system. It is designed to help provide additional safety and meet local fire code requirements.

In Stock Options:

Stock Number	Depth	Width	Use with Beam Length	Capacity
894/3646	36"	46"	8' or 12'	2500 lbs
894/3646	36"	46"	9'	2500 lbs
894/4246	42"	46"	8' or 12'	2500 lbs
894/4252	42"	52"	9'	2500 lbs
894/4846	48"	46"	8' or 12'	2500 lbs
894/4852	48"	52"	9'	2500 lbs



### 4 PALLET RACK FRAME PROTECTOR

- Height = 18"
- Inside Width = 4-5/8"
- Inside Depth = 2-7/8"
- Overall Width = 8"
- Overall Depth = 4-1/2"

SUPPLIER:



Stock Number – 894/SPP-18

Pallet racking frame protectors are constructed from 3/16" thick steel in order to provide a high level of protection you can depend on. All pallet racking frame protectors come fully equipped with powder-coat finish to help prevent rusting and the wear and tear of everyday damage.

Pallet rack frame protectors are specifically designed to help prevent pallet rack uprights from being damaged by forklifts and material handling equipment by deflecting even the strongest of impacts. All pallet rack frame protectors come equipped with a baseplate that has three anchor holes to allow for the frame protector to be installed into any existing pallet rack system.



### 5 BAR STOCK RACKING

- Powder-coat finish
- Up to 600 lbs capacity per arm
- Arm length of 9", 12", 18" and 24"
- All arms attached with a double bracket connection
- Available in single & double-sided configuration

SUPPLIER:



Bar stock racking systems come fully equipped with a powder-coat finish that is specifically designed to stand up to the wear and tear of everyday use.

All bar stock racking systems are designed using standard rack components for light and medium duty applications, making them the perfect storage solution for hand loaded bars, pipes, or long narrow trims.

Stock Number	Dimensions	Capacity
<b>Bar Stock Arms (Capacity per Arm)</b>		
894/WBSA09	9"	600 lbs
894/WBSA12	12"	500 lbs
894/WBSA18	18"	400 lbs
894/WBSA24	24"	300 lbs
<b>Upright Frames</b>		
<b>"L" Frame</b>		
894/WSS96	18"D x 96"H	
<b>"A" Frame</b>		
894/WDS96	32"D x 96"H	
<b>Connector Beams</b>		
894/WCB36	36"W	
894/WCB48	48"W	



### 6 REEL RACKING

- Utilizes standard rack components for use with spools
- Reel adaptors can accommodate spool axles or pipes up to 2" diameter
- With 1,500 lbs capacity per pair of supports

SUPPLIER:



Reel racking is made from an all steel construction, offering strength and durability you can rely on. All reel racking systems come fully equipped with a powder-coat finish that is specifically designed to stand up to the wear and tear of everyday use, while also preventing rusting.

All reel racking systems utilize standard rack components that are perfect for storing spools.

Stock Number	Dimensions
<b>Reel Adaptors</b>	
894/WRA	(1 left + 1 right) 1500lbs cap.
<b>Reel Rod</b>	
894/WT36	36" x 1.315" x .100w Rod
894/WT48	48" x 1.315" x .100w Rod
<b>Upright Frames</b>	
<b>"L" Frame</b>	
894/WSS96	18"D x 96"H
<b>"A" Frame</b>	
894/WDS96	32"D x 96"H
<b>Connector Beams</b>	
894/WCB36	36"W
894/WCB48	48"W



## 1 EZRECT SHELVING TYPE 1

EZRECT shelving type 1 is a completely boltless system that can easily be erected within minutes, making it an ideal storage solution for a wide range of industrial and commercial applications. All EZRECT shelving systems are specifically designed to stand up to even the toughest warehouse environments.

Made up of four basic parts—posts, post connectors, shelf supports, and shelves—EZRECT shelving offers accessibility from both the front and the back of the unit. This shelving system features adjustable shelves and vertical adjustments at 2" intervals, making it easy to maximize the unit's storage space. EZRECT shelving systems are sold either by the piece or as a full unit with five shelf levels, offering a weight capacity up to 2,000 lbs per shelf (shelves sold separately).

**How To Order** – Start each new row with a free-standing "Starter Unit". By using "Add-On" units of the same depth, you can extend the row as long as your needs require.

- Erects in Minutes
- Capacities to 1500 lbs
- Adjustable Shelves
- Accessible Front & Back
- Comes with 5 Shelf Levels
- Shelves Sold Separately
- Completely boltless system
- Four Basic Parts – posts, post connectors, shelf supports and shelves
- Vertical adjustment at 2" intervals for maximum utilization
- Standard colour – Grey Baked Enamel

SUPPLIER:



Dimensions			Starter Unit	Add-on Unit
H	W	D	Stock No.	Stock No.
7'	3'	24"	236/7324S	236/7324A
		36"	236/7336S	236/7336A
		48"	236/7348S	236/7348A
4'	24"	24"	236/7424S	236/7424A
		36"	236/7436S	236/7436A
		48"	236/7448S	236/7448A
6'	24"	24"	236/7624S	236/7624A
		36"	236/7636S	236/7636A
		48"	236/7648S	236/7648A
8'	3'	24"	236/8324S	236/8324A
		36"	236/8336S	236/8336A
		48"	236/8348S	236/8348A
4'	24"	24"	236/8424S	236/8424A
		36"	236/8436S	236/8436A
		48"	236/8448S	236/8448A
6'	24"	24"	236/8624S	236/8624A
		36"	236/8636S	236/8636A
		48"	236/8648S	236/8648A

### OPTIONAL SIZES AVAILABLE

Height: 3', 4', 5', 6', 7', 8', 9', 10', 11', 12', 13', 14', 15', 16'

Depth: 12", 15", 18", 24", 30", 36", 42", 48"

Width: 36", 42", 48", 60", 72", 96"

## 3 EZRECT SHELVING TRIMLINE

EZRECT shelving Trimline systems offer an economical, yet attractive, design that makes it the ideal choice for a wide range of industrial and commercial applications. All EZRECT shelving Trimline systems are made up of four basic parts—posts, post connectors, shelf supports, and shelves—and features a completely boltless system that can be easily erected within minutes.

This type of shelving system is especially ideal for file and record storage, as it offers five shelf levels and can easily be vertically adjusted at 1" intervals. EZRECT shelving

Dimensions					Starter Unit		Add-On Unit		
H	W	D	Stock Number	Stock Number	H	W	D	Stock Number	Stock Number
5'	3'	12"	236/TS5312	236/TA5312	6'	3'	12"	236/TS6312	236/TA6312
		15"	236/TS5315	236/TA5315			15"	236/TS6315	236/TA6315
		24"	236/TS5324	236/TA5324			24"	236/TS6324	236/TA6324
4'	12"	12"	236/TS5412	236/TA5412	4'	12"	12"	236/TS6412	236/TA6412
		15"	236/TS5415	236/TA5415			15"	236/TS6415	236/TA6415
		24"	236/TS5424	236/TA5424			24"	236/TS6424	236/TA6424

- Economical, attractive design
- Erects in Minutes
- File & Record Storage
- Comes with 5 Shelf Levels
- Shelves Sold Separately
- Completely Boltless System
- Four Basic Parts – posts, post connectors, shelf supports and shelves
- Vertical adjustment at 1" intervals
- Standard Colour – Soft Off-White Baked Enamel

SUPPLIER:





## 2 EZRECT MOBILE SHELVING SYSTEMS

- Traditional Shelving requires several aisles
- Mobile Shelving reduces the number of aisles required
- Fewer aisles = More shelving
- Store up to 50% more in less floor space with an EZRECT Mobile Storage System

**SUPPLIER:**



**The Mobile Shelving Advantage**

- Reduce your floor space requirement
- Store product more efficiently and increase storage capacity
- Improve access time and productivity
- Lower your operating costs
- EZR Mobile Storage Systems provide a quick Return On Investment
- The Retail Mobile Shelving Advantage

**Increase the space utilization of your Stockroom**

- Reduce the size of your Stockroom
- Allocate Additional Square footage to retail selling space
- Maximize Sales opportunities through increased stock levels at the point of sales

EZRECT mobile shelving systems are specifically designed to store up to 50% more in less floor space than traditional shelving systems by reducing the number of aisles required. This type of shelving system is ideal for both commercial and industrial applications, as it can help improve access time and productivity, while also lowering operating costs.

This type of shelving system is perfect for increasing storage space utilization, while also maximizing sales opportunities through increased stock levels at the point of sales. EZRECT mobile shelving systems can be customized to accommodate almost any type of shelving brand on the market, including both EZRECT shelving type 1 and EZRECT shelving Trimline products and are available in a wide range of sizes with wood, metal, or wire shelf options.

also boasts a weight capacity up to 950 lbs per shelf (shelves sold separately). All EZRECT shelving Trimline systems are available in a wide range of different sizes and come in the standard Soft Off-White Baked Enamel colour.

**How To Order** – Start each new row with a free-standing "Starter Unit". By using "Add-On" units of the same depth, you can extend the row as long as your needs require.

Dimensions					Starter Unit		Add-On Unit		
H	W	D	Stock Number	Stock Number	H	W	D	Stock Number	Stock Number
7'	3'	12"	236/TS7312	236/TA7312	7'	3'	12"	236/TS7312	236/TA7312
		15"	236/TS7315	236/TA7315			15"	236/TS7315	236/TA7315
		24"	236/TS7324	236/TA7324			24"	236/TS7324	236/TA7324
4'	12"	12"	236/TS7412	236/TA7412	4'	12"	12"	236/TS7412	236/TA7412
		15"	236/TS7415	236/TA7415			15"	236/TS7415	236/TA7415
		24"	236/TS7424	236/TA7424			24"	236/TS7424	236/TA7424

### OPTIONAL SIZES AVAILABLE:

Height: 5', 6', 7', 8', 9', 10', 11', 12'  
 Depth: 12", 15", 18", 24", 30", 36"  
 Width: 24", 36", 39", 42", 48", 60", 66", 72"





**4 BULK STORAGE SHELVING**

Bulk storage shelving systems are the perfect choice for both industrial and commercial applications, as they make it easy to design the perfect storage layout for any space. This type of shelving is made from a sturdy construction that can stand up to the heaviest loads in even the toughest warehouse environments.

All bulk storage shelving systems come in a light grey colour and are extremely easy to assemble and install into almost any warehouse space. Bulk storage shelving systems boast four shelves with beams and are 87" high, making them the ideal storage space for products of a wide variety of different sizes. This type of shelving system is also available with either wood or steel decking and offers a weight capacity between 1025 lbs and 1250 lbs, depending on the shelving size and decking material.

**How To Order** – Start each new row with a free-standing "Starter Unit". By using "Add-On" units of the same depth, you can extend the row as long as your needs require.

- Height 87"
- 4 Shelves With Beams
- Wood or Steel Decking
- Stocked Shelving – Light Grey Colour

SUPPLIER:



WxDxH	Deck Type	Cap. Lbs.	Starter Unit	Add-on Unit
			Stock Number	Stock Number
48"x36"x87"	Wood	1025	691/SRS7301	691/SRA7301
	Steel	1100	691/SRS7302	691/SRA7302
48"x48"x87"	Wood	1025	691/SRS7303	691/SRA7303
	Steel	1100	691/SRS7304	691/SRA7304
96"x36"x87"	Wood	1250	691/SRS7313	691/SRA7313
	Steel	1250	691/SRS7314	691/SRA7314
96"x48"x87"	Wood	1250	691/SRS7315	691/SRA7315
	Steel	1250	691/SRS7316	691/SRA7316

**5 SPIDER OPEN SHELVING**

Spider open shelving systems are a great economical choice when designing the storage layout for any warehouse setting, making them perfect for both industrial and commercial applications. This type of shelving system is made from a sturdy construction that offer strength and durability you can rely on.

All spider open shelving systems work to eliminate front and back swaying through the use of side and back braces. This support system helps ensure that the shelving is able to remain strong and stable under even the heaviest loads. Spider open shelving systems are extremely easy to assemble for any warehouse space and offer easy access to all products being stored. This type of shelving unit comes with six storage shelf levels and is available in a wide range of different sizes, making it easy to find the right fit for your specific warehouse needs. All spider open shelving systems come in a light grey colour.

**How To Order** – Start each new row with a free-standing "Starter Unit". By using "Add-On" units of the same depth, you can extend the row as long as your needs require.

- Comes With 6 Shelf Levels
- Stocked Shelving – Light Grey Colour

SUPPLIER:



Height	Dimensions		Starter Unit	Addon Unit
	Width	Depth	Stock Number	Stock Number
75"	36"	12"	691/SOS6312	691/SOA6312
		15"	691/SOS6315	691/SOA6315
		18"	691/SOS6318	691/SOA6318
		24"	691/SOS6324	691/SOA6324
75"	48"	12"	691/SOS6412	691/SOA6412
		15"	691/SOS6415	691/SOA6415
		18"	691/SOS6418	691/SOA6418
		24"	691/SOS6424	691/SOA6424
87"	36"	12"	691/SOS7312	691/SOA7312
		15"	691/SOS7315	691/SOA7315
		18"	691/SOS7318	691/SOA7318
		24"	691/SOS7324	691/SOA7324
87"	48"	12"	691/SOS7412	691/SOA7412
		15"	691/SOS7415	691/SOA7415
		18"	691/SOS7418	691/SOA7418
		24"	691/SOS7424	691/SOA7424



**6 SPIDER CLOSED SHELVING**

Spider closed shelving systems are made from a sturdy construction that is specifically designed to stand up to even the heaviest loads. This type of shelving is perfect for both industrial and commercial applications in even the toughest work conditions.

All spider closed shelving systems are as simple to assemble and install as open shelving systems. This type of shelving also boasts closed sides and back to help prevent any product spillage from occurring. Spider closed shelving systems come with six shelf levels and are available in a wide range of different sizes and depths, making it easy to find the perfect storage system for your specific warehouse space. All spider closed shelving systems come in a light grey colour.

**How To Order** – Start each new row with a free-standing "Starter Unit". By using "Add-On" units of the same depth, you can extend the row as long as your needs require.

- Comes With 6 Shelf Levels
- Stocked Shelving – Light Grey Colour

SUPPLIER:



Height	Dimensions		Starter Unit	Addon Unit
	Width	Depth	Stock Number	Stock Number
75"	36"	12"	691/SCS6312	691/SCA6312
		15"	691/SCS6315	691/SCA6315
		18"	691/SCS6318	691/SCA6318
		24"	691/SCS6324	691/SCA6324
75"	48"	12"	691/SCS6412	691/SCA6412
		15"	691/SCS6415	691/SCA6415
		18"	691/SCS6418	691/SCA6418
		24"	691/SCS6424	691/SCA6424
87"	36"	12"	691/SCS7312	691/SCA7312
		15"	691/SCS7315	691/SCA7315
		18"	691/SCS7318	691/SCA7318
		24"	691/SCS7324	691/SCA7324
87"	48"	12"	691/SCS7412	691/SCA7412
		15"	691/SCS7415	691/SCA7415
		18"	691/SCS7418	691/SCA7418
		24"	691/SCS7424	691/SCA7424



**7 RECORD STORAGE SHELVING**

Record storage shelving is built from a tough construction that offers strength and durability you can rely on. This type of shelving system is ideal for both commercial and industrial applications, as it can stand up to the wear and tear of everyday use.

All record storage shelving systems are a great economical choice for designing the perfect storage layout in any warehouse setting. This shelving system is quick and easy to assemble and is specifically designed to withstand even the heaviest of loads. Record storage shelving systems come in a light grey colour with four wooden shelves and beams. All record storage shelving systems are 75" high and can hold between 40-80 boxes at a time.

**How To Order** – Start each new row with a free-standing "Starter Unit". By using "Add-On" units of the same depth, you can extend the row as long as your needs require.

- Height 75"
- 4 Shelves With Beams
- Wood Shelves
- Stocked Shelving – Light Grey Colour

SUPPLIER:



Stock Number	Dimensions W x D x H	Box Cap.
<b>Starter Unit</b>		
691/SFS6615	66" x 15" x 75"	40
691/SFS6630	66" x 30" x 75"	80
<b>Add-On Unit</b>		
691/SFA6615	66" x 15" x 75"	40
691/SFA6630	66" x 30" x 75"	80



## 8 CHROME WIRE SHELVING

Chrome wire shelving is made from a simple design that is easy to erect without the need for any special tools.

This type of shelving system boasts an open wire design that can help minimize dust and improve air circulation throughout the warehouse. All chrome wire shelving systems can also be easily adjusted—featuring shelves that can be adjusted at precise 1" intervals and feet that can be adjusted to compensate for surface irregularities—and comes complete with four shelf levels. Chrome wire shelving offers a weight capacity of 800 lbs per shelf, providing strength and durability you can rely on.

**How To Order** – Start each new row with a free-standing "Starter Unit". By using "Add-On" units of the same depth, you can extend the row as long as your needs require.

- Open wire design minimizes dust
- Improves air circulation
- Greater visibility of stored items
- No special tools required
- Shelves can be adjusted at precise 1" intervals
- Adjustable feet compensate for surface irregularities
- Complete Shelving Unit c/w 4 Shelf Levels
- Shelf Capacity – 800 lbs

Complete Shelving Units		
Stock Number	Dimensions D x L x H	
Starter Unit	Addon Unit	
RL059	RL060	18" x 36" x 63"
RL061	RL062	18" x 48" x 63"
RL063	RL064	18" x 60" x 63"
RL065	RL066	18" x 72" x 63"
RL067	RL068	24" x 36" x 63"
RL069	RL070	24" x 48" x 63"
RL071	RL072	24" x 60" x 63"
RL073	RL074	24" x 72" x 63"

Extra Posts	
Stock Number	Height
RL611	33"
RL330	54"
RL331	63"
RL332	74"
RL333	86"

Extra Shelves	
Stock Number	Dimensions D x W
RL036	18" x 36"
RL037	18" x 48"
RL038	18" x 60"
RL039	18" x 72"
RL040	24" x 36"
RL041	24" x 48"
RL042	24" x 60"
RL043	24" x 72"

Accessories	
Stock Number	Description
RL048	Caster 5" no brake
RL049	Caster 5" with brake
RL054	Split Sleeves, 4 per pack
RL055	S-Hook for attaching Addon Units
RL056	Leveling Feet (Die cast and foot bolt)
RL057	Die cast for leveling feet
RL058	Foot bolt for leveling feet



## 9 SLOTTED ANGLE SHELVING

- Pre-Engineered For Fast, Economical, Do-It-Yourself Construction
- Requires No Special Tools Or Skills
- Design and Build Anything to Your Specifications
- Reusable, Needs No Painting, Drilling or Welding
- 14 Gauge Angle
- In Stock – Grey

Slotted angle shelving is made from a strong steel construction that will not rust, splinter, warp, or sliver.

All slotted angle shelving products are pre-engineered for fast, economical construction that can be performed by anyone without any special tools or skills. This type of shelving system is 100% reusable, as it does not require any painting, drilling, or welding. Slotted angle shelving is compatible with other leading makes and models and it can easily be designed and built to fit any specifications.

If you are interested in slotted angle shelving, make a rough sketch showing the dimensions of your space in multiples of 2". Since all angles are pre-measured and marked every 2", one of our team members will be able to help you cut the slotted angle shelving to the desired lengths. The slotted angle shelving can then be bolted together, using gussets and foot plates for additional stability. Slotted angle shelving can be purchased either per foot or in 12" sections and is available with a selection of different accessories.



Stock Number	Description
900/40A	1 1/2" x 1 1/2" Angle/Ft – Cut To Size
900/40A-12	1 1/2" x 1 1/2" Angle – 12' Length
900/40A-NB	Nuts & Bolts 1 1/2" Angle
900/40A-GP	Gusset Plates 1 1/2" Angle
900/60A	1 1/2" x 2 1/2" Angle/Ft – Cut To Size
900/60A-12	1 1/2" x 2 1/2" Angle – 12' Length
900/60A-NB	Nuts & Bolts 2 1/2" Angle
900/CLIPS	Shelf Clips 1 1/2" or 2 1/2" Angle



## 10 WIDESPAN 4000 SHELVING SYSTEMS

Widespan 4000 shelving systems are the ideal universal shelving system for bulk and lightweight items, as well as for high-rise mezzanine or catwalk applications. This type of racking product ranges in sizes from 12" x 36" to 48" x 96" and are available with flooring that can be open steel plank, plywood, or bar grating. The mezzanine floor on Widespan 4000 shelving systems can be used for storage, light assembly work, or as an office, depending on local building codes. This type of racking also allows for almost all of the space beneath the system to be available for use.

**Frames:** Manufactured from 14 gauge steel and welded into an extremely strong structure.

**Front Mount Beams:** Available in 2" and heavy-duty 3". Manufactured from a one-piece 14 gauge rollformed section.

**Side Mounted Beams:** Using side mounted beams as shelf supports provide a cost effective shelving system. The V-type design supports particle board or steel shelving in front and back for added weight capacity. Front face covers board for neat appearance and provides maximum storage space. Beams are adjustable on 1" centres.



- Welded frames ready for quick assembly
- Side mounted beams or front mounted beams
- Particle board shelves or steel shelves
- Shelves supported on beams for extra strength



SUPPLIER:  
**CS SCHAEFER**

**1** **VLM** LOGIMAT VERTICAL LIFT MODULE

LogiMat vertical lift modules are designed to increase stock efficiency and performance by 20%, providing pick rates up to 100 lines per hour. This type of lift module is perfect for both commercial and industrial applications as it can save up to 90% more floor space than other systems, while still keeping inventory clean and secure.

LogiMat vertical lift modules consist of a very large container with two columns of stacked trays, an elevator, and an extractor. When in use, the elevator spans the entire container of trays, selecting the desired individual tray and transferring it to the pick window, eliminating any bending or reaching by the operator. All of the system's vertical travel is done through the use of a rack and pinion driven design for smooth, fast, and precise positioning during insertion and extraction of the trays.

LogiMat vertical lift modules have direct drive motors that are integrated into the vertical lift, which eliminates the need for chains and counterweights. This, in turn, helps reduce operating noise levels and maintenance costs, as there is no need for periodic slack/level adjustments. This type of lift module comes fully equipped with a security door and is easily adjusted so that the counter is at the perfect height and the tray tilts at the right forward angle when delivering parts to the picker.

HELPFUL INFO



**ABOUT MODULAR DRAWER SYSTEMS**

- The sturdiest and the most durable on the market
- Ergonomic
- Efficient
- Accessible
- 17 Drawer Sizes x 10 Drawer Heights = 170 Possible Dimensions

All modular drawer systems come fully equipped with an ergonomic, full-width handle and accessories (integrated lock-in mechanism, lock-out mechanism, lock, etc.), which have been designed down to the smallest detail in order to make work

easier. Additional accessories for increased organization, such as partitions, dividers, plastic bins, groove trays, foam for tools, and hanging file bars, are also available for modular drawer systems. This type of modular drawer system boasts drawers that open 100% of the way for complete content access and are available in 170 possible dimensions.

**ABOUT MODULAR DRAWERS IN SHELVING**

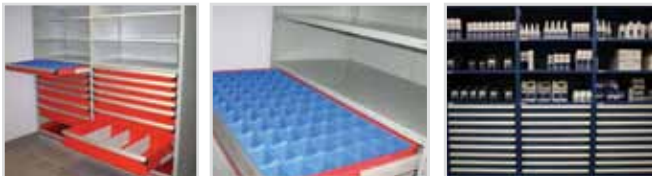

- Can be installed in over 35 brands of shelving
- Easy and quick hook-on assembly for most brands of shelving
- Several dimensions available: 30", 36", 42" and 48" wide by 18" and 24" deep. Same brackets for different dimensions
- 10 drawer heights and 7 side heights available
- Easy and fast installation
- 400 lb capacity per drawer, most durable drawer in the industry

Modular drawers in shelving are perfect for both industrial and commercial applications, as they can easily be installed in over 35 different brands of shelving. This type of modular drawer can also be installed quickly and easily through the use of hook-on assembly.

All modular drawers in shelving products are available in a wide range of dimensions (30", 36", 42" and 48" wide by 18" and 24" deep), using the same brackets for each dimension. With 10 drawer heights and 7 side heights available, it is easy to find the perfect sized drawer for your specifications. Modular drawers in shelving boast a 400 lb per drawer weight capacity, making them the most durable drawers in the industry.



SUPPLIER:

Rousseau modular drawer systems are perfect for both industrial and commercial applications, as they are specifically designed and tested to maintain full load capacities through a high level of cycles without showing any signs of wear and tear. This type of modular drawer system offers strength and durability you can rely on.



HELPFUL INFO

**COMPATIBLE SHELVING BRANDS**

Rousseau modular drawers are the most durable drawers on the market, featuring a weight capacity of 400 lbs per drawer. This type of modular drawer is ideal for both commercial and industrial applications, as it can easily be adapted to fit more than 35 compatible shelving brands available on the market.

Some of the brands that Rousseau modular drawers are ideal for include:

Codes for Brands of Shelving		
Company	Brand	Code
Adapto	Vector	RE45
Aurora	Quik-Lok	RE04
Bilt Industries	Klip-Bilt II	RE18
Borroughs	Steel Shelving	RE02
<b>Easyup</b>	<b>7000</b>	<b>RE31</b>
Equipto	V-Grip	RE29
<b>EZ Rect</b>	<b>Type 1</b>	<b>RE14</b>
<b>EZ Rect</b>	<b>Trimline</b>	<b>RE26</b>
Hallowell	Hi-Tech Shelving	RE07
Inca	Inca-matic	RE10
Lyon	8000	RE16
Metalware	Interlok	RE05
Penco	Clipper	RE08
Penco	Erectomatic	RE07
Republic	Clip Shelving	RE20
<b>Rousseau</b>	<b>"O"</b>	<b>RE01</b>
<b>Rousseau</b>	<b>"Spider"</b>	<b>RE30</b>
Spacesaver	4-post Shelving	RE04
Tennsco	L&T Shelving	RE04
Tennsco	Q-Line	RE43
Tri-Boro	Steel Shelving	RE33
Triple A	600	RE27
Western Pacific	Clip Shelving	RE22
Western Pacific	Deluxe	RE24

Other mounting brackets are available



**2** 4 DRAWERS FOR SHELVING 18H

18" High - 4 Drawers for Shelving  
4 Drawers  
• 3 - 4" drawers  
• 1 - 6" drawer

Stock Number	Dimensions W x D
R5LEC-1801	36" x 18"
R5LEE-1801	36" x 24"
R5LGC-1801	42" x 18"
R5LGE-1801	42" x 24"
R5LHC-1801	48" x 18"
R5LHE-1801	48" x 24"



**3** 5 DRAWERS FOR SHELVING 24H

24" High - 5 Drawers for Shelving  
5 Drawers  
• 3 - 4" drawers  
• 2 - 6" drawer

Stock Number	Dimensions W x D
R5LEC-2401	36" x 18"
R5LEE-2401	36" x 24"
R5LGC-2401	42" x 18"
R5LGE-2401	42" x 24"
R5LHC-2401	48" x 18"
R5LHE-2401	48" x 24"



**4** 7 DRAWERS FOR SHELVING 36H A

36" High - 7 Drawers for Shelving  
7 Drawers  
• 3 - 4" drawers  
• 2 - 6" drawers

Stock Number	Dimensions W x D
R5LEC-3601	36" x 18"
R5LEE-3601	36" x 24"
R5LGC-3601	42" x 18"
R5LGE-3601	42" x 24"
R5LHC-3601	48" x 18"
R5LHE-3601	48" x 24"



**5** 7 DRAWERS FOR SHELVING 36H B

36" High - 7 Drawers for Shelving  
7 Drawers  
• 4 - 4" drawers  
• 2 - 6" drawers  
• 1 - 8" drawer

Stock Number	Dimensions W x D
R5LEC-3603	36" x 18"
R5LEE-3603	36" x 24"
R5LGC-3603	42" x 18"
R5LGE-3603	42" x 24"
R5LHC-3603	48" x 18"
R5LHE-3603	48" x 24"



**6** 8 DRAWERS FOR SHELVING 48H

48" High - 8 Drawers for Shelving  
8 Drawers  
• 8 - 6" drawers

Stock Number	Dimensions W x D
R5LEC-4801	36" x 18"
R5LEE-4801	36" x 24"
R5LGC-4801	42" x 18"
R5LGE-4801	42" x 24"
R5LHC-4801	48" x 18"
R5LHE-4801	48" x 24"



**7** 9 DRAWERS FOR SHELVING 48H

48" High - 9 Drawers for Shelving  
9 Drawers  
• 4 - 4" drawers  
• 4 - 8" drawers  
• 1 - 8" drawers

Stock Number	Dimensions W x D
R5LEC-4803	36" x 18"
R5LEE-4803	36" x 24"
R5LGC-4803	42" x 18"
R5LGE-4803	42" x 24"
R5LHC-4803	48" x 18"
R5LHE-4803	48" x 24"



**8** 10 DRAWERS FOR SHELVING 48H

48" High - 10 Drawers for Shelving  
8 Drawers  
• 6 - 4" drawers  
• 4 - 6" drawers

Stock Number	Dimensions W x D
R5LEC-4805	36" x 18"
R5LEE-4805	36" x 24"
R5LGC-4805	42" x 18"
R5LGE-4805	42" x 24"
R5LHC-4805	48" x 18"
R5LHE-4805	48" x 24"



**9** 11 DRAWERS FOR SHELVING 48H

48" High - 11 Drawers for Shelving  
11 Drawers  
• 4 - 3" drawers  
• 3 - 4" drawers  
• 4 - 6" drawers

Stock Number	Dimensions W x D
R5LEC-4807	36" x 18"
R5LEE-4807	36" x 24"
R5LGC-4807	42" x 18"
R5LGE-4807	42" x 24"
R5LHC-4807	48" x 18"
R5LHE-4807	48" x 24"



**10** 7 DRAWERS FOR SHELVING 48H

48" High 7 Drawers and 1 Front Access Roll-Out Shelf  
• 2 - 3" drawers  
• 3 - 4" drawers  
• 2 - 6" drawers

Stock Number	Dimensions W x D
R5LEC-4809	36" x 18"
R5LEE-4809	36" x 24"
R5LGC-4809	42" x 18"
R5LGE-4809	42" x 24"
R5LHC-4809	48" x 18"
R5LHE-4809	48" x 24"

**SUPPLIER:**



All drawers for shelving systems are made from a sturdy construction that is specifically designed to withstand the wear and tear of everyday use.

**IMPORTANT NOTES FOR ALL THE DRAWER SYSTEMS LISTED ON THIS PAGE:**

• Drawer Partitions are included in models.

• All models include mounting brackets for Spider Shelving.

• For mounting brackets for other brands of shelving, please call for more information.

• Shelving must be ordered separately.

\* Always In Stock

HELPFUL INFO

Our mobile shelving and racking systems are compact, modular structures that provide maximum storage while taking up minimal space. This modular system comes in both electrical and mechanical models, depending on your office needs. Transferring or reconfiguring the system, as well as adding additional rows of storage is easy, giving you one less thing to stress about if your workplace moves or evolves.



WASTED SPACE  
CONVENTIONAL FIXED  
SHELVING LAYOUT.



SPACE SAVED & INCREASED  
PROFITS MOBILE STORAGE  
LAYOUT.



DOUBLED STORAGE CAPACITY,  
MAXIMIZED SPACE &  
INCREASED PROFITS  
MOBILE LAYOUT.

SUPPLIER:



**11 MOBILEX MECHANICAL ASSIST STORAGE**

- Refined space optimization
- **Lower operating costs**
- Improved productivity
- Better organization
- Upgraded building aesthetic



**12 SAFEAISLE POWERED MOBILE STORAGE**

- **100% safety coverage**
- Refined space optimization
- Lower operating costs
- Improved productivity
- Better organization
- Upgraded building aesthetic



**13 QUADRAMOBILE MODULAR FLOORING STORAGE**

- Refined space optimization
- Lower operating costs
- **Improved productivity**
- Better organization
- Upgraded building aesthetic



**14 SMARTSPACE PLUS LIGHT-DUTY STORAGE**

- Refined space optimization
- Lower operating costs
- Improved productivity
- Better organization



**15 QUADRAL LATERAL MOVABLE STORAGE**

- **Improved storage security**
- Optimized space and storage
- Increased workplace productivity
- Better organization



**16 RACK&ROLL 16**

- Refined space optimization
- **Storage consolidation**
- Lower operating costs
- Improved productivity
- Better organization
- **Enhanced inventory management**
- Reduced energy consumption and environmental impact



**17 SAFERAK 32 INDUSTRIAL POWERED MOBILE RACKING**

- **Industry-leading safety measures**
- Storage optimization
- Improved workplace productivity
- **Cost savings**
- Enhanced workflow
- Complete customization
- Reduced environmental impact and energy consumption



**18 SAFERAK 60 INDUSTRIAL POWERED RACKING**

- Enhanced workplace productivity
- Improved safety measures
- **Cost savings and return on investment**
- Optimized workplace storage
- Completed customization
- Cost savings
- **Less energy consumption and a reduced environmental impact**
- Improved workflow



**1 ROLLING LADDERS**

Rolling ladder products are designed to ensure operator safety and to increase productivity by allowing you to take the ladder to where the work is. This product comes in a wide range of sizes and boasts an all steel, bolt together construction that allows for any part to be replaced at any given time.

All rolling ladder products come with a powder-coat finish and a perforated tread design to prevent slipping. No matter what size of rolling ladder you need for your industry, all rolling ladders offer safety features, such as the automatic braking system on 2- to 6-step models or the positive locking system with manual release on 5- to 20-step models. All safety features are specifically designed to ensure the safety of all employees, meeting and exceeding OSHA and ANSI requirements.

- Top platform is 14" D to provide ample working area
- Automatic brake on 2 - 6 step models
- Positive locking system with manual release standard on 7 to 20 step models - optional on 5 & 6 step models
- All Steel - Bolt Together Construction - allows for any part to be replaced
- Powdercoat Finish
- Perforated tread design prevents slipping
- ANSI and OSHA Compliant
- Detailed use and maintenance instructions are sent with each ladder



Stock Number	Steps	Platform Height	Working Height Up To	Hand Rail	Brake Type	Base W x L (inches)	Overall Height
890/L02	2	1' - 6"	7' - 0"	No	Auto	26 x 21	1'-6"
890/L03	3	2' - 3"	7' - 9"	No	Auto	26 x 27	2'-3"
890/L04	4	3' - 0"	8' - 6"	No	Auto	26 x 33	3'-0"
890/L03HR	3	2' - 3"	7' - 9"	Yes	Auto	26 x 27	5'-9"
890/L04HR	4	3' - 0"	8' - 6"	Yes	Auto	26 x 34	6'-6"
890/L05HR	5	3' - 9"	9' - 3"	Yes	Auto	26 x 40	7'-3"
890/L06HR	6	4' - 6"	10' - 0"	Yes	Auto	26 x 45	8'-0"
890/L05HRL	5	3' - 9"	9' - 3"	Yes	Lock	31 x 40	7'-3"
890/L06HRL	6	4' - 6"	10' - 0"	Yes	Lock	31 x 45	8'-0"
890/L07HRL	7	5' - 3"	10' - 9"	Yes	Lock	35 x 51	8'-9"
890/L08HRL	8	6' - 0"	11' - 6"	Yes	Lock	35 x 57	9'-6"
890/L09HRL	9	6' - 9"	12' - 3"	Yes	Lock	35 x 63	10'-3"
890/L10HRL	10	7' - 6"	13' - 0"	Yes	Lock	35 x 69	11'-0"
890/L11HRL	11	8' - 3"	13' - 9"	Yes	Lock	35 x 74	11'-9"
890/L12HRL	12	9' - 0"	14' - 6"	Yes	Lock	35 x 79	12'-6"
890/L13HRL	13	9' - 9"	15' - 3"	Yes	Lock	35 x 84	13'-3"
890/L14HRL	14	10' - 6"	16' - 0"	Yes	Lock	35 x 90	14'-0"
890/L15HRL	15	11' - 3"	16' - 9"	Yes	Lock	35 x 96	14'-9"
890/L16HRL	16	12' - 0"	17' - 6"	Yes	Lock	35 x 104	15'-6"
890/L18HRL	18*	13' - 6"	19' - 0"	Yes	Lock	35 x 114	17'-0"
890/L20HRL	20*	15' - 0"	20' - 6"	Yes	Lock	35 x 126	18'-6"
<b>Extras</b>							
891/LG26	Walk-Through Chain Gate - 26" Wide Ladder Kit						
891/LG30	Walk-Through Chain Gate - 30" Wide Ladder Kit						
890/LS2	Ladder Stabilizer Kit						

\* 18 & 20 step models not tested for ANSI compliancy



**2 ROLLING WORK PLATFORMS**

SUPPLIER:



Rolling work platforms combine code-compliant access with the flexibility to provide for changing workflow. These mobile platforms also offer the efficiency of using one platform for multiple locations, when simultaneous work is not required.

Rolling work platforms offer the most economical way to expand your operating space without moving existing structures or acquiring more floor space. All models come with a perforated tread design to prevent slipping, and all steel, bolt together construction that allows for any part to be replaced separately.

These work platforms also offer safety features, designed to ensure that the platform remains fixed in place when in use. Rolling work platforms are available in two different styles: with a positive locking system and without a positive locking system. Models with a positive locking system allow you to unlock the platform wheels and transport it without any lifting required. Models without a positive locking system feature more of a wheelbarrow style in which the platform must be lifted off its front legs in order to transport it. All rolling work platforms meet and exceed the compliancy standards of both ANSI and OSHA.

- 42" Long top platform
- Models without lock roll "wheelbarrow" style
- Models with lock roll without lifting required
- Positive locking system with manual release on locking models
- All Steel - Bolt Together Construction - allows for any part to be replaced
- Powdercoat Finish
- Perforated tread design prevents slipping
- ANSI and OSHA Compliant
- Detailed use and maintenance instructions are sent with each ladder

Stock Number	No. of Steps	Platform H x W x L (Inches)	Hand Rail	Lock	Overall Length	Overall Height
890/WP3-42	3	27x26x42	No	No	56"	27"
890/WP4-42	4	36x26x42	No	No	61"	36"
890/WP3HR-42	3	27x26x42	Yes	No	57"	69"
890/WP4HR-42	4	36x26x42	Yes	No	62"	78"
890/WP5HR-42	5	45x26x42	Yes	No	68"	87"
890/WP3-42L	3	27x26x42	No	Yes	56"	27"
890/WP4-42L	4	36x26x42	No	Yes	61"	36"
890/WP3HR-42L	3	27x26x42	Yes	Yes	57"	69"
890/WP4HR-42L	4	36x26x42	Yes	Yes	62"	78"
890/WP5HR-42L	5	45x26x42	Yes	Yes	68"	87"
<b>Extras</b>						
891/LG26	Walk-Through Chain Gate - 26" Wide Kit					

**4 TILT AND ROLL LADDERS**

Model 890/L02-T: 2-Step Ladder with Handle (Tilt)

Tilt and roll ladders feature an easy to use two-step ladder design, making it ideal for reaching products and goods on lower warehouse shelves. This type of ladder comes equipped with a powder-coat finish.

- 2-rigid casters replace swivel stem casters
- Pull handle to tilt ladder onto casters
- 300 lbs capacity

SUPPLIER:



**3 PUSH HANDLE LADDER**

Model 890 / L02-HNDL: 2-Step Ladder with Handle (Push)

Push handle ladders are designed to provide easier access to products and goods stored on lower shelves. This type of ladder comes complete with a powder-coat finish to help prevent rusting, as well as the wear and tear of everyday use.

- Standard 2-Step Rolling Ladder
- Includes push handle for easier movement
- 300 lbs capacity

SUPPLIER:





**5 LADDER SHELF TRAY**

**Model 891/LS10: Shelf Tray**

- Recommended for use with rolling ladders of minimum 21" long platforms
- Can be attached to the top back handrails on standard 14"D ladder
- Can be attached to the top back or side handrails on standard 21"D or deeper ladders
- Folds down when not in use
- 19-3/8" x 9-3/8" x 1"H



SUPPLIER:



**6 MECHANICS LADDERS**

**Model 890/L03HR-21-T: 3-Step "Mechanics" Tilt Ladder**  
**Model 890/L04HR-21-T: 4-Step "Mechanics" Tilt Ladder**

Mechanics ladders are constructed from an all steel, bolt together design, and a perforated tread design to prevent slips and falls.

- 21" Long Platform
- All Steel – Bolt together design
- 5" non-marking casters on front
- Wheel guards on front of handrail
- All components are replaceable
- Perforated tread design prevents slipping
- 300 Lb. capacity

- ANSI and OSHA compliant
- Detailed use and maintenance instructions sent with each ladder
- Powder-coat finish



**SERVICE CARTS**

Service carts are designed to help you move equipment or products of all shapes and sizes from one location to another, while also helping increase the efficiency of your business. These service carts feature swivel casters and weight capacities up to 1200 lbs, making it easy for you and your employees to move any item to anywhere in your facility.

All service carts are constructed from heavy gauge steel and feature a durable powder-coat finish that will help protect the cart from some of the wear and tear of everyday use.

- Reversible shelves
- Two 5" non-marking swivel casters
- Two 5" non-marking rigid casters
- Weight capacity: 1200 lbs
- Powder-coat finish

SUPPLIER:



Cart Size W"xL"xH"	A. Stock Number	B. Stock Number	C. Stock Number	D. Stock Number	E. Stock Number
<b>16x30x34</b>	890/1630	890/1630-3			
<b>18x36x34</b>	890/1836	890/1836-3		890/PT-1836	890/ER-1836
<b>24x36x34</b>	890/2436	890/2436-3	890/2436-P	890/PT-2436	890/ER-2436
<b>24x42x34</b>	890/2442	890/2442-3	890/2442-P	890/PT-2442	890/ER-2442
<b>24x48x34</b>	890/2448	890/2448-3	890/2448-P	890/PT-2448	890/ER-2448

**Model Specifications:**

- Standard 2 shelf cart (shelf clearance = 23")
- Standard 3 shelf cart (shelf clearance = 10.25")
- 8" Pneumatic casters for a smooth ride on rough surfaces (shelf clearance = 18")
- Picking list holder which eliminates the inconvenience of handling loose papers
- A newly designed ergonomic handle to prevent strain

## 7 SHELF TRUCKS



- Four shelf models have 15" clearance
- Five shelf models have 10 1/2" clearance
- Height 61"
- Shelves may be reversed for flush surface

**SUPPLIER:**



Stock Number	Shelf Size	Shelves	Overall Length
890/ST-1836-4	18" x 36"	4	42"
890/ST-2436-4	24" x 36"	4	42"
890/ST-2442-4	24" x 42"	4	48"
890/ST-2448-4	24" x 48"	4	54"
890/ST-1836-5	18" x 36"	5	42"
890/ST-2436-5	24" x 36"	5	42"
890/ST-2442-5	24" x 42"	5	48"
890/ST-2448-5	24" x 48"	5	54"

## 8 SECURITY CARTS

Stock Number 890/SC2448-4



- All welded construction
- 2" x 2" x 10GA wire mesh screen on 3 sides and doors
- Double swing doors with padlock hasp
- 3 shelves and solid top
- OA dimensions – 25"W x 55"L x 61"H

**SUPPLIER:**



## 9 DUAL PURPOSE STOCK TRUCKS



3 Shelf Stock Picker and Ladder Truck in one

2 Shelf Stock Picker and Ladder Truck in one

- Spring loaded ladder locks cart in place

- Spring loaded ladder locks cart in place.

**Dimensions:**

- Overall: 46"W x 20"D x 71 1/2" H
- 60"H to the top shelf
- Bottom shelf: 42" x 20"
- Top shelf: 35 1/2" x 20"
- Middle shelf: 36" x 20"
- Top shelf: 30" x 20"
- 25 1/2" shelf clearance
- 2 1/2" shelf tip
- 2 swivel 2 rigid casters
- 5" non marking casters
- All welded construction
- Powder coat finish
- Capacity - 1200 lbs.

**Dimensions:**

- Overall : 46" x 20" x 63 1/2"H
- Bottom shelf : 42" x 20"
- Top shelf: 35 1/2" x 20"
- 37"H to top of the shelf
- 2 1/2" shelf lip
- 2 swivel 2 rigid casters
- 5" non marking casters
- All welded construction
- Powder coat finish
- Capacity - 1200 lbs.

**SUPPLIER:**



Stock Number	Number of Shelves
890/362	2
890/364	3



Tubular welded steel carts are made from solid all welded steel construction for long lasting strength, durability, and dependability.

All tubular welded steel carts have a frame made with all welded 1" diameter tubing with slatted decks to minimize dust accumulation. These carts also feature 2 swivel and 2 rigid 5" non-marking casters that are specifically designed to roll smoothly in order to create easier transport of products. Tubular welded steel carts are available in both single-shelf carts and two-shelf carts, making them ideal for different loading heights.

Tubular welded steel carts are designed to withstand even the toughest work environments. These carts offer a weight capacity of 1200 lbs and come with a powder-coat finish to help prevent wear and tear caused by everyday use.

- Capacity 1200 lbs
- Powder-coat finish

**SUPPLIER:**



Stock Number	Shelf Size	Shelf Type	Caster Type
A. 890/SM58B	38" X 16"	TUBE	5" swivel/rigid, 8" centre wheels
B. 890/SM2241	41" X 22"	TUBE	5" swivel/rigid, 8" centre wheels
C. 890/L5B	36" X 16"	TUBE	5" swivel/rigid
D. 890/H5B	36" X 16"	TUBE	5" swivel/rigid
E. 890/L5B-ST	36" x 16"	SOLID	5" swivel/rigid
F. 890/H5B-ST	36" X 16"	SOLID	5" swivel/rigid

**10 HEAVY DUTY WOOD PLATFORM TRUCK**

Heavy duty wood platform trucks provide an alternative surface to the steel top platform trucks. The steel frame on this platform truck is designed to absorb shocks, as well as to provide the wood deck with a level of superior protection.



- Heavy-Duty wood platform truck
- Steel frame absorbs shock
- Removable handle
- 2 swivel and 2 rigid casters
- Powder coat finish
- Capacity - 2200 lbs.



Stock Number	Wheel Size	Deck Size
890/W2448-8	8"	24" x 48"
890/W3060-8	8"	30" x 60"

**11 MEDIUM DUTY STEEL PLATFORM TRUCK**

Medium duty steel platform trucks boast a steel frame that is specifically designed to absorb shocks, and a removable handle that allows for larger load sizes.



- Steel platform trucks
- Removable handle
- 2 swivel and 2 rigid casters
- Powder coat finish
- Capacity - 1200 lbs.



Stock Number	Wheel Size	Deck Size	Capacity
890/S2436-5	5"	24" x 36"	1200 Lbs
890/S2442-5	5"	24" x 42"	1200 Lbs
890/S2448-5	5"	24" x 48"	1200 Lbs

**12 WAGON TRUCKS**



- Available with Steel or Wood deck surfaces
- Powder coat finish
- Capacity - 1500 lbs.



Stock Number	Deck Type	Deck Size	Capacity
890/WW2448-P	Wood	24" x 48"	1500
890/WW3060-P	Wood	30" x 60"	1500
890/WS2448-P	Steel	24" x 48"	1500
890/WS3060-P	Steel	30" x 60"	1500

**13 LIQUOR OR MERCHANDISE STOCK TRUCK**

Stock Number 890/EK210

Liquor or merchandise stock trucks are constructed with a steel frame and wood decking to provide strength and durability that can stand up to even the toughest warehouse applications.



- Well designed for retail or warehouse, hotel stocking and more
- Wood finish platform
- Dimensions - 18"W x 42"L x 37"H
- Platform size 42" x 18"
- Powder coat finish
- Capacity - 1200 lbs.



**14 HD STEEL PLATFORM TRUCK**

Steel Platform Truck - Heavy Duty model

- Heavy-Duty reinforced steel deck
- Steel frame absorbs shock
- Removable handle
- 2 swivel and 2 rigid casters
- Powder coat finish
- Capacity - 2400 lbs.



Stock Number	Wheel Size	Deck Size	Capacity
890/S2448-6	6" Moldon Rubber	24" x 48"	2100 Lbs
890/S2448-8	8" Moldon Rubber	24" x 48"	2400 Lbs
890/S2448-P	10" Pneumatic	24" x 48"	1800 Lbs
890/S3060-6	6" Moldon Rubber	30" x 60"	2100 Lbs
890/S3060-8	8" Moldon Rubber	30" x 60"	2400 Lbs
890/S3060-P	10" Pneumatic	30" x 60"	1800 Lbs
890/S3672-6	6" Moldon Rubber	36" x 72"	2100 Lbs
890/S3672-8	8" Moldon Rubber	36" x 72"	2400 Lbs
890/S3672-P	10" Pneumatic	36" x 72"	1800 Lbs

**15 FOLDING HANDLE PLATFORM TRUCK**



- Move supplies, forms and light equipment around the shop or office
- Quick-release handle folds flat for easy storage
- Heavy gauge steel construction; non-skid vinyl coated deck
- 34" handle height
- Vinyl wrap around bumper protects walls and furniture
- Rubber casters

Stock Number	Platform Dimensions W' x L"	Capacity Lbs.	Caster Size
MK988	19" x 29"	440	4"
MK989	23" x 35"	660	5"

**16 DRYWALL CART**

Stock Number 890/DC139



- Overall Dimensions = 24"W x 44"L x 44"H
- Platform Dimensions = 15"W x 44"L x 14"H
- 10 gauge steel deck
- Deck angled at 10°
- 1" lip on front edge of deck
- 1-5/16" diameter tubular handle
- 8" Moldon Rubber Wheels, swivel, 2 rigid
- Powder coated finish
- 2000 Lbs Capacity

**17 COMMERCIAL HAND TRUCK**

Stock Number  
890/HL85



- Height 50"
- Width 19"
- Nose plate size 7" x 13 5/8"W
- Capacity 900 Lbs
- Semi-pneumatic wheels 8" x 2"
- Weight 27 Lbs
- Powder coated finish

SUPPLIER:



**18 ROUGH TERRAIN HAND TRUCK**

Stock Number  
890/HL10P



- Full pneumatic wheels 10" x 4"
- Height 50"
- Width 21"
- Nose Size 7" x 13 3/4"
- Capacity 500lbs
- Weight 29lbs
- Powder-coat Finish

SUPPLIER:



**19 ECONOMY HAND TRUCK**

Stock Number  
890/802



- Height 45"
- Width 17"
- Nose plate size 7" x 13 5/8"W
- Capacity 400lbs
- Semi-pneumatic wheels 8" x 1 1/2"
- Weight 22lbs
- Powder coated finish

SUPPLIER:



**20 ALL PURPOSE HAND TRUCK**

Stock Number  
890/804



- Pneumatic wheels 10" x 4"
- Height 45"
- Width 21"
- Nose Size 7" x 13 1/2"
- Capacity 400lbs
- Weight 25lbs
- Powder-coat Finish

SUPPLIER:



**21 PAIL TRUCK**

Stock Number  
890/105



- Semi-Pneumatic wheels 8" x 2"
- Height 50"
- Width 19"
- Nose Size 7" x 13 3/4"
- Capacity 500lbs
- Weight 27lbs
- Powder-coat Finish

SUPPLIER:



**22 BAGGAGE TRUCK**

Stock Number  
890/980



- Rubber Wheels 8" x 1 1/2"
- Height 50"
- Width 19"
- Fold Down Nose 10" x 22"
- Capacity 500lbs
- Weight 33lbs
- Powder-coat Finish

SUPPLIER:



**23 WAREHOUSE TRUCK**

Stock Number  
890/3051



- Rubber Wheels 10" x 2 1/2"
- Height 52"
- Width 20"
- Nose Size 6" x 20"
- Capacity 850lbs
- Weight 54lbs

SUPPLIER:



**24 BAG MASTER HAND TRUCK**

Stock Number  
890/3071



- Rubber wheels 10" x 2 1/2"
- Height = 52"
- Width = 22"
- Nose Size = 8" x 10"
- Capacity = 850lbs
- Weight = 46lbs

SUPPLIER:



**25 CHAIR MOVER HAND TRUCK**

Stock Number  
890/801



- Semi-pneumatic wheels 8" x 2"
- Height 50"
- Width 19"
- Capacity 400lbs
- Weight 31lbs
- Powder-coat Finish

SUPPLIER:



**26 TWO IN ONE HAND TRUCK**

Stock Number  
890/120



- Semi-pneumatic wheels 8" x 2" with guards
- Height 50" as a hand truck
- Platform Truck Bed 14" x 42"
- Width 19"
- Casters 3"
- Capacity 500lbs as hand truck
- Capacity 700lbs as platform truck
- Weight 48lbs

SUPPLIER:



**27 LIQUOR HAND TRUCK**

Stock Number  
890/EK190



- Frame designed for one- or two-handed operation
- Strong all welded tubular construction.
- Semi-Pneumatic Wheels 8" x 2"
- Height 50"
- Width 19"
- Nose Size 5 1/2" x 12"
- Capacity 500lbs
- Weight 28lbs
- Powder-coat Finish

SUPPLIER:



**28 BEER PALLET HAND TRUCK**

Stock Number  
890/EK200

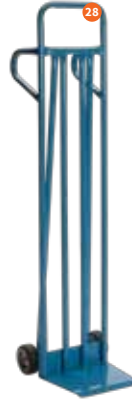

- Frame designed for one- or two-handed operation.
- Strong all welded tubular construction
- Mold on rubber wheels 5"x2"
- Height 59"
- Width 15 1/2"
- Nose Size 13 1/2" x 10"
- Capacity 500 lbs
- Weight 30 lbs
- Powder-coat Finish

SUPPLIER:



**29 BREAD TRAY HAND TRUCK**

Stock Number  
890/2002



- 60" O.A.H
- 8" Semi pneumatic wheels
- Fork dimensions - 3" x 20" long
- 17" wide frame

SUPPLIER:



**30 MINI BEER**

Stock Number  
891/X-MP001



- Designed for use with single liquor cases
- Frame designed for one- or two-handed operation
- Strong all welded tubular construction
- Mold-on rubber wheels 5" x 2"
- Height - 60"
- Width - 10"
- Depth - 20"
- Nose Size - 12" x 8"
- Capacity - 500 lbs
- Powder-coat Finish

SUPPLIER:



**31 LARGE CYLINDER HAND TRUCK**

Stock Number  
890/CC5



- Comes with large tool tray
- Capacity:
  - Acetylene up to 365 cu. ft.
  - Propane up to 100lbs.
  - Oxygen up to 300 cu. ft.
  - Up to 700lbs
- Solid Rubber Wheels 14" x 3"
- Base 13" x 24"
- Weight 55lbs
- Powder coated finish

SUPPLIER:



**32 LARGE CYLINDERS PNEUMATIC**

Stock Number  
890/CC5-16



- Comes with large tool tray
- Capacity:
  - Acetylene up to 365 cu. ft.
  - Propane up to 100lbs.
  - Oxygen up to 300 cu. ft.
  - Up to 600lbs
- Pneumatic wheels 16" x 4"
- Base 13" x 24"
- Weight 55lbs
- Powder coated finish

SUPPLIER:



**33 MEDIUM CYLINDER HAND TRUCK FRONT TO BACK**

Stock Number  
890/CC3



- Capacity:
  - Acetylene up to 320 cu. ft.
  - Oxygen up to 244 cu. ft.
  - 400lbs.
- Front to back load style
- Base 9 1/2" x 17"
- Axle 5/8"
- Wheels 8" x 1 3/4"
- Weight 21lbs
- Powder coated finish

SUPPLIER:



**34 MEDIUM CYLINDER HAND TRUCK SIDE BY SIDE**

Stock Number  
890/CC4



- Capacity:
  - Acetylene up to 320 cu. ft.
  - Oxygen up to 244 cu. ft.
  - 400lbs.
- Base Plate 9 1/2" x 18 3/4"
- Base 9 1/2" x 17"
- Axle 5/8"
- Wheels 8" x 1 3/4"
- Weight 25lbs
- Powder coated finish

SUPPLIER:



**35 SINGLE CYLINDER**

Stock Number  
890/CC9



- 15" W x 46" H x 15"D
- c/w stair climbers
- Semi - Pneumatic wheels 8"x2"
- Capacity 500lbs.
- Weight 28 lbs.
- Powder coated finish

SUPPLIER:



## 36 APPLIANCE TRUCK PROFESSIONAL MODEL

Stock Number  
890/1504

Appliance truck professional model products are constructed from a welded tubular frame with a powder-coat finish that is specifically designed to provide strength and economy that you can rely on. This type of appliance truck is ideal for both commercial and industrial applications. All appliance truck professional models also come equipped with vinyl non-marking bumpers on contact points to prevent damage to appliances or walls during transportation.



SUPPLIER:



- Semi-pneumatic wheels 5" x 2"
- Height 60"
- Width 24"
- Capacity 800 lbs
- Weight 45 lbs

## 37 APPLIANCE TRUCK GENERAL PURPOSE MODEL

Stock Number  
890/1284

Appliance truck general purpose model products are made from a welded tubular construction that offers strength and durability in even the toughest warehouse applications. This type of appliance truck is perfect for both industrial and commercial uses. All appliance truck general purpose models come fully equipped with a powder-coat finish to help prevent rusting, while standing up to the damage caused by everyday use.



SUPPLIER:



- Semi-Pneumatic Wheels 8" x 2"
- Height 60"
- Width 24"
- Capacity 800lbs
- Weight 50lbs
- Powder-coat Finish

## 38 APPLIANCE TRUCK RENTAL INDUSTRY MODEL

Stock Number  
890/1289

Appliance truck rental industry model products are made from a welded tubular frame that can stand up to the wear and tear of everyday commercial and industrial applications. This type of appliance truck also comes fully equipped with a powder-coat finish to help prevent rusting. All appliance truck rental industry model products offer a simple and highly workable design.



SUPPLIER:



- Semi-Pneumatic Wheels 8" x 2"
- Height 60"
- Width 24"
- Capacity 800lbs
- Weight 52lbs
- Powder-coat Finish

## 39 ECONOMY DRUM TRUCK



Economy drum trucks are made from a sturdy all welded steel construction, featuring a vertical design that mounts to the drum, making it easy to slightly tilt the drum during transportation. All economy drum trucks also come fully equipped with a powder-coat finish that is specifically designed to help prevent wear and tear from everyday use, as well as rusting from occurring.

- Straight up design holds full loads on an incline
- Heavy-duty mold on rubber wheels move easily

SUPPLIER:



Product	Stock Number
Economy Drum Truck	890/3001
10" Pneumatic Wheels	890/3001P

## 40 DELUXE DRUM TRUCK

Stock Number  
890/3000



Deluxe drum trucks are constructed from a sturdy all welded steel construction that offers durability you can count on. All deluxe drum trucks also come fully equipped with a powder-coat finish, which is designed to stand up to the wear and tear of everyday use in even some of the toughest warehouse environments.

- Excellent load balance for easy handling
- Spring loaded, floating axle helps cushion the load
- Self-standing feature keeps truck vertical when not in use
- Heavy duty mold on rubber wheels move easily

SUPPLIER:



## 41 DISPENSING DRUM TRUCK

Stock Number  
890/3004



Dispensing drum trucks are specifically designed to handle dispensing liquids with the same ease as transporting full drums. With its all welded tubular construction and powder-coat finish, dispensing drum trucks are perfect for withstanding work in even the harshest warehouse environments.

- Dispenses liquids with the same ease as moving full drums
- Unique rollers on frame so drums can be rotated without removing them from the truck
- Special chine hooks fit neatly beneath spigot, won't interfere with dispensing

SUPPLIER:



## 42 PLASTIC DRUM TRUCK

Stock Number  
890/3004



Plastic drum trucks are constructed from an all welded steel tubular construction that offers durability and dependability you can count on. All plastic drum trucks also come fully equipped with a powder-coat finish to help prevent rusting, while also standing up to the wear and tear of everyday use in even the toughest warehouse applications.

- Adjustable belt with ratchet tightener
- Handles most 25-45 gallon capacity drums

SUPPLIER:



# DOLLIES AND FURNITURE DOLLIES

## 43 DRUM CRADLES

Drum cradles are constructed from heavy gauge tube construction that provides a level of strength and durability that can withstand even the harshest commercial or industrial applications. All drum cradles also come fully equipped with a powder-coat finish that is specifically designed to help prevent rusting, while also standing up to the wear and tear of everyday use.

Stock Number  
890/3014

- Complete with 4 rigid wheels
- Capacity 1000 lbs



Stock Number  
890/3015

- Complete with 2 rigid and 2 swivel wheels
- Capacity 1000 lbs.



SUPPLIER:



## 44 DRUM DOLLY

Stock Number  
890/3040

Drum dollies are made from heavy-duty welded steel and come complete with a powder-coat finish to help prevent rusting.



- 24" diameter dollies move 45 gallon drums smoothly and easily
- Turn 360° on four swivel casters
- 1000 lb capacity

SUPPLIER:



## 45 FURNITURE DOLLY

Stock Number  
890/1360

Furniture dollies are made from a tubular steel frame and carpeted wood construction that offers strength and durability you can rely on. All furniture dollies also come fully equipped with a powder-coat finish to help prevent rusting.



- Dimensions – 17" x 26"
- 3" Swivel Casters
- 800 Lbs Capacity

SUPPLIER:



## 46 PIANO DOLLY

Stock Number  
890/1355

All piano dollies are constructed using a tubular steel frame combined with carpeted wood in order to provide a higher level of strength and durability. Piano dollies also come fully equipped with a powder-coat finish to help prevent rusting.



- Dimensions – 17" x 26"
- 5" 2 Swivel 2 Rigid Casters
- 800 Lbs Capacity

SUPPLIER:



# BOX & TILT TRUCKS

## 47 TILT TRUCKS

- One-man handling, moving & dumping of wet or dry materials, food or waste
- Seamless black polyethylene containers
- All welded steel chassis
- Two large fixed front wheels and smaller swivel casters at rear



Stock Number	Cubic Yards	Capacity Lbs	Dimensions L x W x H	Front Wheel Type	Back Wheel Type
MN980	5/8	500	57" x 28" x 38"	8" Moldon Rubber	4" Non-Marking Rubber
MN981	5/8	500	57" x 28" x 38"	10" Moldon Rubber	5" Non-Marking Rubber
MN982	1.1	500	66" x 34" x 43"	12" Moldon Rubber	5" Non-Marking Rubber
MN983	1.1	500	66" x 34" x 43"	12" Moldon Rubber	5" Non-Marking Rubber

## 48 PRY DOLLY

Stock Number  
MF870

- Move heavy boxes, die blocks and machinery
- Heavy-duty nose plate gets under the load, 6" steel or wooden handle gives tremendous leverage
- Come with 5" x 2" polyurethane casters
- Use in pairs to move large objects without the need of a separate dolly
- Handle: Wood
- Capacity Lbs.: 4250
- Nose Plate: 6" x 3"



## 49 BOX TRUCKS



- Polyethylene construction
- 4" threadguard casters
- Corner caster placement
- Treated plywood undercarriage
- Body Colour = Grey

Stock Number	Cubic Feet	Capacity Lbs	Dimensions L x W x H	Caster Placement
NC460	5	200	21" x 21" x 27"	Corner
NC461	6	200	33" x 19" x 28"	Corner
NC462	7	200	33" x 23" x 24"	Corner
NC463	7	200	24" x 24" x 38"	Corner
NA001	8	300	35" x 25" x 25"	Corner
NC464	9	300	48" x 19" x 28"	Corner
NA002	12	400	39" x 27" x 30"	Diamond
NA004	12	800	39" x 27" x 31"	Corner
NA003	12	800	39" x 27" x 31"	Diamond

Stock Number	Cubic Feet	Capacity Lbs	Dimensions L x W x H	Caster Placement
NC465	15	400	41" x 29" x 31"	Diamond
*NC466	15	800	41" x 29" x 32"	Corner
NC467	15	800	41" x 29" x 32"	Diamond
NA006	16	400	43" x 31" x 33"	Diamond
NA007	16	800	43" x 31" x 34"	Corner
NA008	16	800	43" x 31" x 34"	Diamond
NC468	19	800	43" x 31" x 36"	Corner
NC469	19	800	43" x 31" x 36"	Diamond

\* Always In Stock

**1 PLASTIC STACKABLE BINS**



- Industry-Leading Hanging & Stacking Bins
- **Efficient:** Control inventories, shorten assembly times, minimize parts handling
- **Functional:** Heavy-duty bins securely stack atop each other, sit on shelving, and hang from Akro-Mils racks, panels, rails and carts
- **Durable:** Molded of industrial-grade polymers, AkroBins are resistant to weak acids and alkalis. Water, rust and corrosion-proof
- **Guaranteed:** AkroBins are guaranteed not to crack or break under normal load conditions as stated by Akro-Mils 1-year limited warranty

SUPPLIER:



Stock Number	Outside Dimensions L x W x H (inches)	Bin Dividers Stock Numbers
004/30-210	5 3/8 x 4 1/8 x 3	004/40-210
004/30-220	7 3/8 x 4 1/8 x 3	004/40-220
004/30-230	10 7/8 x 5 1/2 x 5	004/40-230
004/30-235	10 7/8 x 11 x 5	004/40-230
004/30-239	10 3/4 x 8 1/4 x 7	004/40-239
004/30-240	14 3/4 x 8 1/4 x 7	004/40-245
004/30-250	14 3/4 x 16 1/2 x 7	004/40-250

\* For other sizes, options and colours, please call for assistance.

**2 PLASTIC SHELF BINS**



- Economy Bins for Shelving & Vertical Storage Units
- **Efficient:** Shelf Bins work with 12" 18" and 24" deep shelving, pick racks or vertical storage and retrieval units
- **Durable:** Industrial-grade polymer bins outlast corrugated bins – paying for themselves in reduced replacement costs. Bins won't spread or crack when loaded. One-piece construction is waterproof and resistant to grease or oil
- **Nestable:** Shelf Bins nest when empty to conserve space

SUPPLIER:



\*\*Small Bin Cup  
Stock Number 004/30-101\*\*

\*\*Large Bin Cup  
Stock Number 004/30-102\*\*

\* For other sizes, options and colours, please call for assistance.

Stock Number	Outside Dimensions W x H x L (inches)	Bin Cups /Bin		Dividers Stock Numbers
		Small	Large	
004/30-110	2 3/4 x 4 x 12	3	-	-
004/30-120	4 1/8 x 4 x 12	5	2	004/40-120
004/30-130	6 5/8 x 4 x 12	9	4	004/40-130
004/30-150	8 3/8 x 4 x 12	11	4	004/40-150
004/30-170	11 1/8 x 4 x 12	15	6	004/40-170
004/30-128	4 1/8 x 4 x 18	8	3	004/40-120
004/30-138	6 5/8 x 4 x 18	15	6	004/40-130
004/30-158	8 3/4 x 4 x 18	15	6	004/40-150
004/30-178	11 1/8 x 4 x 18	25	12	004/40-170
004/30-124	4 1/8 x 4 x 24	11	4	004/40-120
004/30-164	6 5/8 x 4 x 24	21	8	004/40-130
004/30-184	8 3/4 x 4 x 24	25	8	004/40-150
004/30-174	11 1/8 x 4 x 24	35	16	004/40-170

**3 ATTACHED LID CONTAINERS**



- **Functional:** Reusable shipping, distribution, order picking and storage containers
- **Secure:** Attached lids snap securely closed to protect contents from dust and damage
- **Interworking:** Containers interwork for easy pallet loading
- **Stackable & Nestable:** Containers stack on closed lids and nest in open lids

SUPPLIER:



Buckhorn Attached Lid Containers		
Stock Number	Outside Dimensions L x W x H (inches)	Inside Dimensions L x W x H (inches)
*004/AR151413	14 3/4 x 13 1/2 x 13 1/2	11 1/4 x 11 1/4 x 12
*004/AR151415	14 3/4 x 13 1/2 x 15 1/4	11 1/4 x 11 1/4 x 14
*004/AR201207	20 x 11 3/4 x 7 1/2	17 x 9 x 6
*004/AC211509	21 3/4 x 15 1/4 x 9 3/4	18 1/2 x 13 x 8 1/2
*004/AC211512	21 3/4 x 15 1/4 x 13	18 x 12 1/2 x 11 1/4
*004/AS221312	22 1/2 x 13 x 13	18 3/4 x 10 x 11 3/4
*004/AR242012	24 x 19 1/2 x 12 3/4	20 1/2 x 16 1/2 x 10 3/4
*004/AR271709	27 x 17 x 9 3/4	24 x 14 x 8
*004/AR271712	27 x 17 x 12 1/2	23 1/2 x 13 3/4 x 11
*004/AS282115	28 x 20 3/4 x 15 1/2	25 x 18 x 14
*004/AS342420	34 x 24 x 19 3/4	30 x 19 1/2 x 18

\*Dimensions rounded to the nearest 1/4"

**4 INDUSTRIAL STRAIGHT WALL CONTAINERS**

- **Functional:** Reusable shipping, storage and work-in-process containers
- **Solid:** Smooth inner walls for easy, sanitary cleaning
- **Durable:** Injection-molded from industrial-grade polymers



Stock Number	Outside Dimensions L x W x H (inches)		
*004/SW120705F1	12	7 1/2	5
*004/SW151205F1	15	12	5
*004/SW151207F1	15	12	7 1/2
*004/SW151209F1	15	12	9 1/2
*004/SW241504A2	24	15	4
*004/SW241505F1	24	15	5
*004/SW241507F1	24	15	7 1/2
*004/SW241509F1	24	15	9 1/2
*004/SW241511F1	24	15	11
*004/SW241514F1	24	15	14 1/2
*004/SW242207F1	24	22	7 1/2
*004/SW242209F1	24	22	9
*004/SW242211F1	24	22 1/2	11
*004/SW242214F1	24	22 1/2	14 1/2
*004/SW32150802	32	15	7 1/2
*004/SW48150802	48	15	7 1/2

\*Lids not included. \*Dimensions rounded to nearest 1/2"

**MULTI-PURPOSE STRAIGHT WALL CONTAINERS**



- **Functional:** Reusable shipping, storage and work-in-process containers
- **Solid:** Smooth inner walls for easy, sanitary cleaning
- **Mesh:** Allow air ventilation and drainage
- **Durable:** Injection-molded from industrial-grade polymers
- **Colours:** Red, Grey

Stock Number	Outside Dimensions L x W x H (inches)	Inside Dimensions L x W x H (inches)
<b>5 Mesh Sides &amp; Base</b>		
*004/37208	15 3/4 x 11 3/4 x 8 1/4	14 1/4 x 10 1/4 x 8
*004/37608	23 3/4 x 15 3/4 x 8 1/4	22 1/4 x 14 1/4 x 8
*004/37612	23 3/4 x 15 3/4 x 12 1/4	22 1/4 x 14 1/4 x 12
*004/37616	23 3/4 x 15 3/4 x 16 1/8	22 1/4 x 14 1/4 x 16
<b>6 Mesh Sides &amp; Solid Base</b>		
*004/37278	15 3/4 x 11 3/4 x 8 1/4	14 1/4 x 10 1/4 x 8
*004/37678	23 3/4 x 15 3/4 x 8 1/4	22 1/4 x 14 1/4 x 8
*004/37672	23 3/4 x 15 3/4 x 12 1/4	22 1/4 x 14 1/4 x 12
*004/37676	23 3/4 x 15 3/4 x 16 1/8	22 1/4 x 14 1/4 x 16
<b>7 Solid Sides &amp; Solid Base</b>		
*004/37288	15 3/4 x 11 3/4 x 8 1/4	14 1/4 x 10 1/4 x 8
*004/37688	23 3/4 x 15 3/4 x 8 1/4	22 1/4 x 14 1/4 x 8
*004/37682	23 3/4 x 15 3/4 x 12 1/4	22 1/4 x 14 1/4 x 12
*004/37686	23 3/4 x 15 3/4 x 16 1/8	22 1/4 x 14 1/4 x 16

\*For other sizes, options and colours, please call for assistance.

**8 LOUVERED HANGING SYSTEMS**



Louvered hanging systems are perfect for both industrial and commercial applications, as they offer a flexible, yet secure, storage solution for a wide range of different parts and products. All louvered hanging systems can stand up to the wear and tear of everyday use without cracking or slipping.

Stock Number	Description	Dimensions W x H (inches)
004/30-618	Louvered Panel	18 x 19
004/30-636	Louvered Panel	36 x 19
754/LP3	Louvered Panel	24 3/4 x 25
754/LP4	Louvered Panel	18 3/4 x 73
754/LP5	Louvered Panel	25 x 50
004/98-600	Bench Rack	27 3/4 x 21
004/98-636	Bench Rack	36 x 21
004/30-653	Louvered Floor Rack	35 3/4 x 75 1/8

Compatible with "Stackable" or "Hanging" Bins.

**9 BIN RAIL HANGING SYSTEMS**



SUPPLIER:  
**AKRO-MILS**

Bin rail hanging systems are available in a variety of options, making it easy to find the perfect solution for a wide range of industrial and commercial applications. This type of plastic bin system is made from sturdy construction, offering a high level of strength and durability you can depend on.

Stock Number	Description	Dimensions L x W x H (inches)
004/30-006	Rack, 1 Sided 12 Rail	36 x 14 x 53
004/30-008	Rack, 1 Sided 16 Rail	36 x 14 x 53
004/30-812	Bin Cart	39 x 24 x 37
004/30-012	Rack, 2 Sided 12 Rail	36 x 20 x 53
004/30-016	Rack, 2 Sided 16 Rail	36 x 20 x 53
004/30-148	Wall Mounted Bin Rail	48 x 3
004/30-424	Mobile Kit, Casters	Add 5 1/2"H

**10 SUPER SIZED PLASTIC BINS**



SUPPLIER:  
**AKRO-MILS**

- Industry-Leading Large-Capacity Hanging & Stacking Bins
- **Capacity:** Large-capacity storage to improve organization and workflow
- **Stackable:** Heavy-duty bins securely stack atop each other, sit on shelving, carts or dollies
- **Durable:** Molded of industrial-grade polymers, Super-Size AkroBins are resistant to weak acids and alkalis. Water, rust and corrosion-proof
- **Guaranteed:** Super-Size AkroBins are guaranteed not to crack or break under normal load conditions as stated by Akro-Mils 1-year limited warranty

Stock Number	Outside Dimensions L x W x H (inches)	Inside Dimensions L x W x H (inches)
004/30-255	10 7/8 x 16 1/2 x 5	9 3/4 x 15 x 4 3/4
004/30-265	18 x 8 1/4 x 9	17 1/8 x 6 3/4 x 8 1/4
004/30-270	18 x 16 1/2 x 11	17 1/8 x 14 3/4 x 10 1/4
004/30-280	20 x 12 3/8 x 6	16 7/8 x 10 11/16 x 5 3/8
004/30-281	20 x 12 3/8 x 8	16 7/8 x 10 11/16 x 7 3/8
004/30-282	20 x 12 3/8 x 12	16 7/8 x 10 11/16 x 11 3/8
004/30-283	20 x 18 3/8 x 12	16 7/8 x 16 9/16 x 11 3/8
004/30-290	29 1/4 x 18 3/8 x 12	26 1/8 x 16 9/16 x 11 3/8

\*For other sizes, options and colours, please call for assistance.

**11 HEAVY DUTY PLASTIC STACKABLE CONTAINERS**



- Heavy-duty polypropylene containers are water proof, oil/chemical resistant
- Guaranteed not to break
- Reinforced rib design prevents spreading when stacked or loaded
- Molded lip at rear for use with louvered panels
- Extra wide stacking ledge prevents slippage
- Molded slots for I.D. labels
- Optional dividers increase versatility
- Uniform tare weight ideal for weigh counting
- Available in Red/Blue/Yellow/Green

SUPPLIER:  
**SCHAEFER**

Stock Number	Outside Dimensions L x W x H (inches)	Bin Dividers Stock Number
754/LF110	3 x 4 x 2	-
754/LF211	6 x 4 x 3	754/ZW211
754/LF221	9 x 6 x 5	754/ZW221
754/LF321	14 x 8 x 6	754/ZW321
754/LF322	14 x 8 x 8	754/ZW322
754/LF341	14 x 18 x 6	754/ZW341
754/LF531	20 x 12 x 6	754/ZW531
754/LF532	20 x 12 x 8	754/ZW532
754/LF533	20 x 12 x 12	754/ZW533
754/LF543	20 x 18 x 12	-
754/LF743	28 x 18 x 12	-

**13 NEST AND STACK TOTES**



SUPPLIER:  
**AKRO-MILS**

- **Extremely Durable Totes**
- **Functional:** Ideal for shipping, transfer and storage applications
- **Stackable & Nestable:** Stack with or without lids for storage and shipping. Nested when empty
- **Durable:** Strong, industrial-grade polymer will not rust, corrode or bend out of shape even when fully loaded
- **Cost-Effective:** Long service life resulting in lower replacement costs
- **FDA-Sanctioned:** NSTs are manufactured from FDA-sanctioned materials

Stock Number	Outside Dimensions L x W x H (inches)	Lid Stock Number
004/35-180	18 x 11 x 6	004/35-181
004/35-190	19 1/2 x 15 1/2 x 10	004/35-191
004/35-200	19 1/2 x 13 1/2 x 8	004/35-201
004/35-230	23 1/2 x 19 1/2 x 13	004/35-231
004/35-240	23 1/2 x 15 1/2 x 12	004/35-241
004/35-300	29 1/2 x 19 1/2 x 15	004/35-301

**12 STACK AND NEST CONTAINERS**



- All SSI stack and nest containers are strong and versatile
- Unlimited uses in the storing and shipping of materials
- Stack when filled and nest easily when empty, minimizing storage and transport costs
- Easy to clean, with no sharp corners
- Resists most industrial solvents
- Made from high density polyethylene
- Available in Red, Yellow, Blue or Green

Stock Number	Dimensions L x W x H (inches)	Lid Stock Number
754/FB604	24 x 16 x 14	754/FBD604
754/FB603	23 x 15 x 12	-
754/FB600	24 x 16 x 10	754/FBD600
754/FB650	26 x 20 x 6	-
754/FB601	23 x 15 x 8	754/FBD601
754/FB530	22 x 13 x 7	-

**14 GIANT STACKABLE BINS**



- Stackable Bins Perfect for Heavy, Bulky Items
- **Stackable:** Bins stack to form tall, stable storage arrangements on floors or standard industrial shelving
- **Capacity:** 75-lb. weight capacity
- **Durable:** Durable, industrial-grade polymer
- will not rust, corrode or bend out of shape even when fully loaded
- **Cost-Effective:** Longer service life resulting in lower replacement costs

SUPPLIER:  
**AKRO-MILS**

Stock Number	Outside Dimensions L x W x H (inches)	Inside Dimensions L x W x H (inches)
004/13-017	15 1/4 x 19 7/8 x 12 7/16	13 5/8 x 17 1/2 x 12 1/4

## 14 SALT AND SAND CONTAINERS



- Roto Molded of LLDPE
- Impact Resistant
- Double Wall, Lockable Lid (lock not included)
- Nestable
- Water Resistant
- Forklift Accessible
- 5 Year Warranty



Stock Number	Cu. Ft.	Dimensions L x W x H (inches)	Cap. Lbs
*004/TSSOS5.5	5.5	34"x24"x24"	500
*004/TSSOS11	11	42"x29"x30"	1000
*004/TSSOS18	18	48"x33"x34"	1750
*004/TSSOS36	36	72"x36"x36"	3500

## 15 EXTRA DUTY BULK BOX



- Drop-doors and four-way forklift entry improve ergonomics and handling efficiency
- Superior durability for reliable performance
- Backed by a one-year limited warranty
- 100% recyclable HDPE
- Colours: Blue or Black
- Lids are available for all models



Stock Number	Outside Dimensions (inches)			Capacity (LBS)	Colour
	W	D	H		
<b>Common Sizes</b>					
*004/BN484525	48	45	25	2500	Black
*004/BN484534	48	45	34	2500	Black / Blue
<b>Specialty Sizes</b>					
*004/BN323034	32	30	34	2000	Black
*004/BN484535	48	45	35	2000	Black
*004/BN484539	48	45	39	2000	Black
*004/BN484541	48	45	41	2000	Black
*004/BN484544	48	45	44	2000	Black
*004/BN484551	48	45	51	2000	Black

## 16 HEAVY DUTY BULK BOX



- Feature steel corner hit plates to deflect fork tines
- Three recessed steel base runners for added stacking strength
- Drop-doors and four-way forklift entry improve ergonomics and handling efficiency
- Superior durability for reliable performance
- Customization and identification options available
- Backed by a one-year limited warranty
- 100% recyclable HDPE
- Capacity - 2,500 lbs
- Lids available for all models



Stock Number	Outside Dimensions (inches)		
	W	D	H
<b>Common Sizes</b>			
*004/BH484034	48	40	34
*004/BH484534	48	45	34
<b>Specialty Sizes</b>			
*004/BH484025	48	40	25
*004/BH484525	48	45	25

## 17 MULTI-PURPOSE FIXED WALL CONTAINER



- Four-way forklift entry improves handling efficiency
- Superior durability for reliable performance
- Backed by a one-year limited warranty
- 100% recyclable HDPE
- Lids available for all models



Stock Number	Outside Dimensions (inches)			Capacity (LBS)	Colour
	W	D	H		
<b>Common Sizes</b>					
*004/BF484429	48	44	29	700	Black
<b>Specialty Sizes</b>					
*004/BF422928	42	29	28	900	Black

## 18 MULTI-PURPOSE FIXED WALL CONTAINER



- 32, 64 and 96 gallons
- 120, 240 and 360 litres
- Available in charcoal grey, green and blue

Stock Number	Capacity (Litres)	Size D x W x H (inches)
754/GMT120	120	22 x 19 x 37
754/GMT240	240	29 x 23 x 42
754/GMT360	360	35 x 24 x 43

# SELF DUMPING STEEL HOPPERS

## 19 SELF DUMPING STEEL HOPPERS

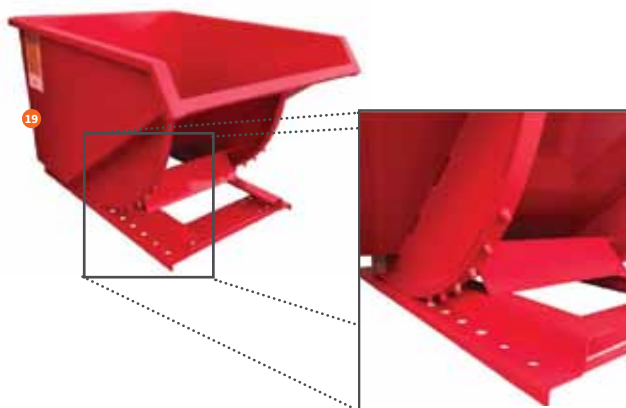

- Perfectly balanced to roll forward when released and dump completely, then automatically return to upright, locked position
- Reinforced steel locking latch with spring loaded safety catch
- Formed smooth edge around top and pouring lip for extra strength and safety
- All-welded steel plate construction designed for forklift handling of heavy/bulky scrap
- Comes with Safety Pull Chain and Anti-Tip Retainer Chain
- Red rust-resistant finish
- Hoppers also available in 3/16" and 1/4" Steel
- Casters for Hoppers are available in 6" or 8" and come with 2 rigid and 2 swivel
- Capacity: 4000 lbs
- Conforms to ANSI/TSDF B56.1 Safety Standard

SUPPLIER:



Hoppers				
Stock Numbers	Capacity (Cu. Yds.)	Dimensions HxWxL (inches)	Steel Spec	Wt. Lbs.
800/SDH050	1/2	32" x 45" x 49"	10 Ga.	385
800/SDH075	3/4	35" x 41" x 58"	10 Ga.	420
800/SDH100	1	43" x 41" x 63"	10 Ga.	505
800/SDH150	1 1/2	43" x 53" x 63"	10 Ga.	560
800/SDH200	2	43" x 65" x 63"	10 Ga.	610
800/SDH300	3	55" x 65" x 79"	10 Ga.	850
800/SDH400	4	63" x 65" x 79"	10 Ga.	970

Casters Kits		
Stock Numbers	Caster Type	Caster Size
800/P6	Phenolic	6"
800/P8	Phenolic	8"
800/S6	Steel	6"
800/S8	Steel	8"

# CORRUGATED PARTS BINS

## 20 CORRUGATED PARTS BINS

- Ideal for storing any loose small parts
- Constructed of durable corrugated fibreboard
- Available in depths of 12" and 18"
- Widths ranging from 2" to 12"
- 3 5/8" deep bin dividers are available in all widths
- Shipped knocked down



Corrugated Parts Bins		
Stock Number		Dimensions W" x H"
12" x 4 1/2"	18" Deep	
CB063	CB056	2" x 4 1/2"
CB065	CB058	4" x 4 1/2"
CB066	CB059	6" x 4 1/2"
CB067	CB060	8" x 4 1/2"
CB053	CB055	12" x 4 1/2"
Corrugated Bin Dividers		
Stock Number		Dimensions W" x H" x L"
CB071		1 3/4" x 4 1/8" x 3 5/8"
CB072		2 3/4" x 4 1/8" x 3 5/8"
CB073		3 3/4" x 4 1/8" x 3 5/8"
CB074		5 3/4" x 4 1/8" x 3 5/8"
CB075		7 3/4" x 4 1/8" x 3 5/8"

## 21 METAL STACKING BASKETS



- Increase productivity
- maximize floor space
- Cupped legs provide easy stacking and prevent floor damage.
- 34 1/2" W x 40 1/2" D x 32 5/8" H
- Inside depth is 24 3/4"
- Underclearance is 4 3/4"
- Half gates fold down for easy access while stacked.
- Capacity 3000 lbs

SUPPLIER:



## 22 BULK STACKING CRADLES

Stock Number 890 / SR4248: Stacking Rack



- Welded 2" sq. tubing steel construction
- Designed for storage of loose and palletized goods
- Holds up to 4000 lbs. per rack
- Can be stacked 4 high
- OA dimensions – 44.5"W x 50.5"L x 13"H

SUPPLIER:



## SMALL PARTS BOXES



- Compartment boxes, racks and bases
- Manufactured of prime cold rolled steel
- Racks and boxes are finished in rust and acid resistant baked enamel finish
- Designed to hold scoop compartment boxes
- Racks are reinforced for strength and support loaded boxes in the open position without tilting
- Positive stops prevent accidental spillage
- Small box dimensions – 13 3/8" W x 9 1/4" D x 2" H
- Large box dimensions – 18" W x 12" D x 3" H
- Compartment boxes, racks and bases sold separately

### 24 Drawers – Small Series

Stock Number	Compartments
CB015	12
CB017	16
CB023	20
CB026	21
CB029	24
CA979	Adjustable

### 24 Cabinets – Small Series

Stock Numbers	Description	Dimensions
CA972	4 Drawer Housing	15 1/4"W x 11 3/4"D x 11 1/4"H
CA975	6 Drawer Housing	15 1/4"W x 11 3/4"D x 16 3/8"H
CA983	Base For Housing	15 1/4"W x 12 1/8"D x 15 1/8"H

### 23 Drawers – Large Series

Stock Number	Compartments
CA986	12
CA989	16
CA992	20
CA995	21
CA997	24
CB002	32
CA977	Adjustable

### 23 Cabinets – Large Series

Stock Numbers	Description	Dimensions
CA963	2 Drawer Housing	20"W x 15 3/4"D x 8 1/8"H
CA965	4 Drawer Housing	20"W x 15 3/4"D x 15"H
CA980	Base For Housing	20 3/8"W x 16"D x 15 1/8"H

## 25 BOLT BINS



Stock Number	Key	Bins	Drawer Size W" x H"	Cabinet W" x H"
CA154		72	4 x 4 1/2	33 3/4 x 42
CA149	B	40	4 x 4 1/2	33 3/4 x 23 7/8
CA151	C	42	5 3/8 x 5 1/2	33 3/4 x 42
CA152		56	4 7/8 x 5 1/8	33 3/4 x 42
CA133		16	4 x 5 1/8	33 3/4 x 11 1/2
CA136		24	5 3/8 x 5 1/2	33 3/4 x 23 7/8
CA157	G		Optional Base	

- Full braced industrial quality won't twist
- Fully assembled
- Hemmed lip prevents spills
- Provides space for identification 12" deep

26 WRITE ON MAGNETIC TAGS



- 3 standard widths available
- Cut 24" lengths to custom size
- Available in bulk rolls
- Standard product thickness is 0.020"

All write on magnetic tags feature a newly formulated write on/wet erase vinyl top coating that makes marking with a standard wet erase marker extremely simple. The special wet erase feature on these tags is designed to help keep tags clean and clear for extended periods of time and can easily be cleaned with a damp cloth.

Cut to Size:	
Stock Numbers	Dimensions W x L (Inches)
500/MAG1-03	1 x 3
500/MAG1-04	1 x 4
500/MAG1-06	1 x 6
500/MAG1-24	1 x 24
500/MAG2-03	2 x 3
500/MAG2-04	2 x 4

Cut to Size:	
Stock Numbers	Dimensions W x L (Inches)
500/MAG2-06	2 x 6
500/MAG2-24	2 x 24
500/MAG3-04	3 x 4
500/MAG3-06	3 x 6
500/MAG3-08	3 x 8
500/MAG3-24	3 x 24

Bulk Rolls:	
Stock Numbers	Dimensions W x L (Inches)
RH698	1" x 50'
RH699	2" x 50'
RH700	3" x 50'

CABINETS & LOCKERS  
SAFETY STORAGE CABINETS

1 PAINT STORAGE CABINETS



- Multiple shelves are ideal for 1 – gallon paint cans (Class III Liquids)
- Cabinets are available in 20, 40, 60 and 96 – gallon capacities
- U-Loc™ handle comes with double key set or accepts optional padlock for greater security
- Haz-Alert™ reflective warning labels offer visibility under dark conditions
- Durable red powder coat finish easily identifies contest and is highly chemical resistant
- FM approved
- Meets NFPA and OSHA regulations

Stock Number	Door Type	Cap. Gal.	Adjustable Shelves	Exterior Dimensions W x D x H (Inches)
SAQ079	1 Door Manual	20	2	23 1/4 x 18 x 44
SAQ081	2 Doors Manual	40	3	43 x 18 x 44
SAQ084	2 Doors Manual	60	5	43 x 18 x 65
SAQ087*	2 Doors Manual	96	5	34 x 34 x 65

Extra Shelves	
Stock Number	Description
SAP839	Extra Shelf for 40 – Gallon Cabinets
SAQ028	Extra Shelf for 60 – Gallon Cabinets

\*Codes state that not more than 60 gallons may be Class I and Class II liquids\*

2 FLAMMABLE STORAGE CABINETS



- Double wall welded 18-gauge steel construction with 1 1/2" of insulating air space
- Doors self-latch for easy and secure closure
- U-Loc™ handle comes with 2 keys or accepts optional padlock for greater security
- Two 2" flame arrester vents and ground wire connection screw
- 2" deep leak-proof sill
- Adjustable leveler legs, and galvanized SpillSlope™ shelves
- Haz-Alert™ reflective warning labels offer visibility under dark conditions
- Durable yellow powdercoat finish
- FM approved and meets NFPA and OSHA requirements

Stock Number	Door Type	Cap. Gal.	Adjustable Shelves	Exterior Dimensions W x D x H (Inches)
SAP509	2 Doors Manual	30	1	43 x 18 x 44
SAQ021	2 Doors Self-Closing	30	1	43 x 18 x 44
SAP510	2 Doors Manual	45	2	43 x 18 x 65
SAQ023	2 Doors Self-Closing	45	2	43 x 18 x 65
SAQ024	2 Doors Manual	60	2	34 x 34 x 65
SAQ025	2 Doors Self-Closing	60	2	34 x 34 x 65
SAQ026*	2 Doors Manual	90	2	43 x 34 x 65
SAQ027*	2 Doors Self-Closing	90	2	43 x 34 x 65

Extra Shelves	
Stock Number	Description
SAP839	Extra Shelf for 30 and 45-Gallon Cabinets
SAQ028	Extra Shelf for 60-Gallon Cabinets
SAQ029	Extra Shelf for 90-Gallon Cabinets

\*Codes state that not more than 60 gallons may be Class I and Class II liquids\*

3 INSULATED FLAMMABLE STORAGE CABINETS



- ULC Approved – 2" Fibre Insulated
- Double welded 18-gauge steel construction, filled with a fire-proof insulation
- Full length piano-hinged doors with three point lock on doorTwo 2" flame arrester vents and ground wire connection screw
- 2" deep leak-proof sill
- Adjustable galvanized shelves on 1/2" centres
- Zinc-plated leveler legs
- Colour – Safety Yellow

Cabinets				
Stock Number	Door Type	Cap. Gal.	Adjustable Shelves	Exterior Dimensions W x D x H (Inches)
SA087	2 Doors Manual	30	1	44 x 19 x 45
SA088	2 Doors Self-Closing	45	2	44 x 19 x 66

Extra Shelves & Accessories	
Stock Number	Description
SA086	Extra Shelf for SA087 and SA088
DA623	Insulated Grounding Wire c/w C-Clamp and Clip
DA622	Flexible Bonding Wire c/w Two Clips
DA621	Flexible Bonding Wire c/w C-Clamp and Clip

## GAS CYLINDER CABINETS



- Heavy-duty construction
- Wire mesh doors and walls for venting
- Warning labels included
- Padlock hasp for added security
- Safety Yellow Powdercoat Finish
- Each cabinet comes with steel bottom shelf, not shown in images
- Each cabinet comes with 4 - 9/16" holes for anchoring

SUPPLIER:



\*\*Images for reference only; style may vary from exact product shown\*\*

### 4 Oxygen Gas (9-inch Diameter Cylinders)

Stock Number	Dimensions W x D x H (inches)	Cylinder Capacity
890/OG10N	33 x 34 1/2 x 70	10
890/OG20N	66 x 34 1/2 x 70	20

### 5 Liquid Propane (35 lb. Cylinders)

Stock Number	Dimensions W x D x H (inches)	Cylinder Capacity
890/LP05N	33 x 34 1/2 x 36	5
890/LP10N	33 x 34 1/2 x 70	10
890/LP20N	66 x 34 1/2 x 70	20

\*Constructed to meet or exceed strict CSA International B149-2-0 Propane Storage and Handling Code. Cylinders must be stored vertically at all times\*

## 6 HI DENSITY SECURITY BIN CABINET



- Deep-door bin cabinet
- Secure storage for parts, tools, and other inventories
- Unique shielded padlock hasp
- Heavy duty 16 gauge steel cabinet measures
- 38"W x 24"D x 72"H
- Louvered hanging panels welded to the cabinets back panel
- Powder coated grey finish

Stock Number	Description	Bin Colour
CB441	Cabinet Only	-
CB443	Cabinet with Bins	Blue
CB444	Cabinet with Bins	Red
CB445	Cabinet with Bins	Yellow

\*Cabinets with bins include the following assortment of AkroBins\*

\*\*42ea. 004/30-210 - 42ea. 004/30-220 - 18ea. 004/30-230 - 12ea. 004/30-240 - 4ea. 004/30-250\*\*

## 7 COMBINATION BIN SECURITY CABINET



Combination bin security cabinets are made from an all welded heavy-duty 16-gauge construction, making them the ideal choice for keeping precision tools, valuable parts, and small assemblies secure in even the busiest warehouse environments.

Stock Number	Description	Bin Colour
CB442	Cabinet Only	-
FB025	Extra Shelf	-
CB446	Cabinet with Bins	Blue
CB447	Cabinet with Bins	Red
CB448	Cabinet with Bins	Yellow

\*Cabinets with Bins include 84 AkroBins - 004/30-210\*

**8 SUPPLY CABINET**



- Commercial Quality Cabinets Offer Strength Style And Savings
- All Welded Construction
- 150 lbs Shelf Capacity
- 36" W x 18" D x 72" H

SUPPLIER:



Stock Number	Colour
500/SC1	Beige
500/SC2	Grey
Extra Shelves	
500/SCS1	Beige
500/SCS2	Grey

**9 SUPPLY CABINET COUNTER HEIGHT**



Stock Number	Colour
500/LC1	Beige
Extra Shelves	
500/SCS1	Beige

- Commercial Quality Cabinets Offer Strength Style And Savings
- All Welded Construction
- 150 lbs Shelf Capacity
- 36" W x 18" D x 42" H

SUPPLIER:



**10 WARDROBE CABINET**



Stock Number	Colour
500/WC1	Beige
500/WC2	Grey

- Commercial Quality Cabinets Offer Strength Style And Savings
- All Welded Construction
- 150 lbs Shelf Capacity
- 36" W x 18" D x 72" H

SUPPLIER:



**11 COMBINATION CABINET**



- Commercial Quality Cabinets Offer Strength Style And Savings
- All Welded Construction
- 150 lbs Shelf Capacity
- 36" W x 18" D x 72" H

SUPPLIER:



Stock Number	Colour
500/CC1	Beige
500/CC2	Grey

**12 JUMBO CABINET**



Stock Number	Colour
500/JC1	Beige
500/JC2	Grey
Extra Shelves	
500/JCS1	Beige
500/JCS2	Grey

- Commercial Quality Cabinets Offer Strength Style And Savings
- All Welded Construction
- 150 lbs Shelf Capacity
- 48" W x 24" D x 78" H

SUPPLIER:



**13 HEAVY DUTY DEEP STORAGE CABINET**



All heavy duty deep storage cabinets come fully equipped with a specially designed padlock hasp that cannot be accessed by bolt cutters or other means. This type of cabinet also comes with four reinforced main shelves and 6" adjustable mini shelves in each 4" deep hinged door, providing a capacity that is unmatched by any other cabinet on the market. Heavy duty deep storage cabinets are 38" wide x 24" deep x 72" high and are available with additional shelves.

Stock Number	Description
FB024	Cabinet
FB025	Extra Shelf (Cabinet)
FB026	Extra Shelf (Door)

\*\*Order Extra Shelves as Required\*\*

**14 HEAVY DUTY DRAWER CABINETS**



- Sturdy and distinct appearance that works in all sorts of different environments
- 10 drawer heights and 7 drawer side heights are available
- True North American dimensions which allow for perfect modularity
- Housing with pre-determined fixing zones for installation of accessories: work surfaces, shelves, etc
- 400 lb capacity per drawer. The most heavy-duty in the industry

Stock Number	Product
<b>/R5AEE-5803</b> 36"W x 24"D x 60"H 11 Drawers Light Grey Housing #071 Avalanche Blue Drawers #055	 <b>* Always In Stock</b>
<b>/R5AHE-5803</b> 48"W x 24"D x 60"H 11 Drawers Light Grey Housing #071 Avalanche Blue Drawers #055	 <b>* Always In Stock</b>

SUPPLIER:



**15 HEAVY DUTY MOBILE DRAWER CABINETS**



- The integrated Lock-In mechanism is easily activated with one hand (right or left)
- The full-width ergonomic handle ensures a smooth and comfortable motion when opening the drawer
- A variety of drawer accessories are available, such as: partitions, dividers, plastic bins, protective foam, etc
- Polyurethane casters with high quality roller bearing systems make moving the cabinet easy and do not leave marks. Total-lock brake available.
- Several housing accessories are available such as: foldaway shelves, hanging side cabinets, laminated wood tops, etc.

SUPPLIER:



Stock Number	Product
<b>/R5BEE-3005 + RC32-3624-01</b> 36"W x 24"D x 37-1/2" 5 Drawers 6" HD Casters (2 rigid, 2 swivel with locks) Steel top with Rubber Mat (RC32) Light Grey Housing #071 Avalanche Blue Drawers #055	

**\* Always In Stock**

LOCKERS  
**DELUXE METAL LOCKERS**

**1 DELUXE METAL LOCKERS**

- Frames are rigid welded 16 gauge steel construction to prevent warping or twisting
- Laminated honeycomb core, double panel doors for strength and sound proofing
- Continuous door stop to prevent door damage
- Double strength hinges welded to frame
- Lock formed body to side connections

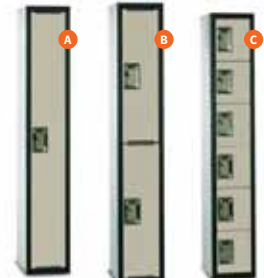

Stock Number	Bank Size	Openings per Bank	Openings per Locker
<b>A Single Tier</b>			
<b>430/ST1</b>	1	1	1
<b>430/ST2</b>	2	2	1
<b>B Double Tier</b>			
<b>430/DT1</b>	1	2	2
<b>430/DT2</b>	2	4	2
<b>C Six Tier</b>			
<b>430/6T1</b>	1	6	6
<b>430/6T2</b>	2	12	6

Optional Number Plates - Available to identify locker. Fits in handle box.  
Order 1 per door opening.

Stock Number. 430/PLATES

WORK CENTRE OVERVIEW



Rousseau work centre systems can easily be reconfigured, which means that it can be changed to fit your evolving needs by simply adding accessories. This type of work centre is available in several dimensions and a wide variety of worksurfaces (painted steel, stainless steel, laminated wood, laminated Acrylic/PVC, and laminated and dissipative plastic tops) to choose from.

1 BASIC WORKBENCH



- 1 Top of Your Choice
- 2 Legs
- 1 Stringer

All basic workbenches are comprised of your choice of top, two legs, and one stringer for a completely solid and sturdy worksurface. This type of workbench is available with a steel top, a plastic laminate top, or a laminated hardwood top.

SUPPLIER:



Stock Number	Dimensions W x D x H
<b>Steel Top</b>	
693/WS001	60" x 24" x 34"
693/WS002	60" x 30" x 34"
693/WS003	60" x 36" x 34"
693/WS004	72" x 24" x 34"
693/WS005	72" x 30" x 34"
693/WS006	72" x 36" x 34"
<b>Plastic Laminate Top</b>	
693/WS007	60" x 30" x 34"
693/WS008	72" x 30" x 34"
693/WS009	72" x 36" x 34"
<b>Laminated Hardwood Top</b>	
693/WS010	60" x 30" x 34"
693/WS011	72" x 30" x 34"
693/WS012	72" x 36" x 34"

2 WORKBENCH WITH LOWER SHELF



- 1 Top of Your Choice
- 2 Legs
- 2 Shelves
- 1 Stringer

All workbenches with a lower shelf come fully equipped with a solid top, two legs, two shelves, and one stringer. This type of workbench is available with a selection of different top materials, including steel, plastic laminate, and laminated hardwood.

3 WORKBENCH WITH LOWER SHELF AND DRAWER UNIT



- 1 Top of Your Choice
- 2 Legs
- 2 Shelves
- 1 Stringer

4 WORKBENCH WITH CABINET



- 1 Top of Your Choice
- 1 Leg
- 1 Cabinet

This type of workbench is available with a selection of different tops, such as steel tops, plastic laminate tops, and laminated hardwood tops.

Stock Number	Dimensions W x D x H
<b>Steel Top</b>	
693/WS013	60" x 24" x 34"
693/WS014	60" x 30" x 34"
693/WS015	60" x 36" x 34"
693/WS016	72" x 24" x 34"
693/WS017	72" x 30" x 34"
693/WS018	72" x 36" x 34"
<b>Plastic Laminate Top</b>	
693/WS019	60" x 30" x 34"
693/WS020	72" x 30" x 34"
693/WS021	72" x 36" x 34"
<b>Laminated Hardwood Top</b>	
693/WS022	60" x 30" x 34"
693/WS023	72" x 30" x 34"
693/WS024	72" x 36" x 34"

Stock Number	Dimensions W x D x H
<b>Steel Top</b>	
693/WS025	60" x 24" x 34"
693/WS026	60" x 30" x 34"
693/WS027	60" x 36" x 34"
693/WS028	72" x 24" x 34"
693/WS029	72" x 30" x 34"
693/WS030	72" x 36" x 34"
<b>Plastic Laminate Top</b>	
693/WS031	60" x 30" x 34"
693/WS032	72" x 30" x 34"
693/WS033	72" x 36" x 34"
<b>Laminated Hardwood Top</b>	
693/WS034	60" x 30" x 34"
693/WS035	72" x 30" x 34"
693/WS036	72" x 36" x 34"

Stock Number	Dimensions W x D x H
<b>Steel Top</b>	
693/WS037	60" x 24" x 34"
693/WS038	60" x 30" x 34"
693/WS039	60" x 36" x 34"
693/WS040	72" x 24" x 34"
693/WS041	72" x 30" x 34"
693/WS042	72" x 36" x 34"
<b>Plastic Laminate Top</b>	
693/WS043	60" x 30" x 34"
693/WS044	72" x 30" x 34"
693/WS045	72" x 36" x 34"
<b>Laminated Hardwood Top</b>	
693/WS046	60" x 30" x 34"
693/WS047	72" x 30" x 34"
693/WS048	72" x 36" x 34"

SUPPLIER FOR THE THREE WORKBENCHS SHOWN ABOVE:



Rousseau work centre systems are specifically designed to offer a multitude of different layouts and accessories, making it easy to create the perfect workspace for your exact needs. This type of work centre is ideal for both industrial and commercial applications, as it is built to withstand the wear and tear of everyday use.

**5 WORKBENCH WITH TWO CABINETS (OPTION A)**



- 1 Top of Your Choice
- 2 Cabinet

All workbenches with two cabinets (option A) come fully equipped with four drawers and one full-height cabinet. Choose from a selection of different tops (steel top, plastic laminate top, and laminated hardwood top) and workbench sizes.

**6 WORKBENCH WITH TWO CABINETS (OPTION B)**



- 1 Top of Your Choice
- 2 Cabinet

Workbenches with two cabinets (option B) are available with a range of different tops (steel top, plastic laminate top, and laminated hardwood top) and come fully equipped with three drawers and two half-height cabinets. All drawers and doors on workbenches with two cabinets (option B).

**7 WORKBENCH WITH TWO CABINETS (OPTION B)**



- 1 Top of Your Choice
- 2 Legs
- 1 Sliding Door With Lock
- 2 Side Panels
- 1 Back Panel
- 3 Shelves
- 2 Leg Crossbars

Stock Number	Dimensions W x D x H
<b>Steel Top</b>	
693/WS049	60" x 24" x 34"
693/WS050	60" x 30" x 34"
693/WS051	60" x 36" x 34"
693/WS052	72" x 24" x 34"
693/WS053	72" x 30" x 34"
693/WS054	72" x 36" x 34"
<b>Plastic Laminate Top</b>	
693/WS055	60" x 30" x 34"
693/WS056	72" x 30" x 34"
693/WS057	72" x 36" x 34"
<b>Laminated Hardwood Top</b>	
693/WS058	60" x 30" x 34"
693/WS059	72" x 30" x 34"
693/WS060	72" x 36" x 34"

Stock Number	Dimensions W x D x H
<b>Steel Top</b>	
693/WS061	60" x 24" x 34"
693/WS062	60" x 30" x 34"
693/WS063	60" x 36" x 34"
693/WS064	72" x 24" x 34"
693/WS065	72" x 30" x 34"
693/WS066	72" x 36" x 34"
<b>Plastic Laminate Top</b>	
693/WS067	60" x 30" x 34"
693/WS068	72" x 30" x 34"
693/WS069	72" x 36" x 34"
<b>Laminated Hardwood Top</b>	
693/WS070	60" x 30" x 34"
693/WS071	72" x 30" x 34"
693/WS072	72" x 36" x 34"

Stock Number	Dimensions W x D x H
<b>Steel Top</b>	
693/WS073	60" x 24" x 34"
693/WS074	60" x 30" x 34"
693/WS075	60" x 36" x 34"
693/WS076	72" x 24" x 34"
693/WS077	72" x 30" x 34"
693/WS078	72" x 36" x 34"
<b>Plastic Laminate Top</b>	
693/WS079	60" x 30" x 34"
693/WS080	72" x 30" x 34"
693/WS081	72" x 36" x 34"
<b>Laminated Hardwood Top</b>	
693/WS082	60" x 30" x 34"
693/WS083	72" x 30" x 34"
693/WS084	72" x 36" x 34"

**8 WORKBENCH WITH CABINET AND UPPER SHELF**



- 1 Top of Your Choice
- 1 Cabinet
- 1 Back Stop
- 2 Shelf Supports
- 1 Shelf

Stock Number	Dimensions W x D x H
<b>Steel Top</b>	
693/WS085	60" x 24" x 34"
693/WS086	60" x 30" x 34"
693/WS087	60" x 36" x 34"
693/WS088	72" x 24" x 34"
693/WS089	72" x 30" x 34"
693/WS090	72" x 36" x 34"
<b>Plastic Laminate Top</b>	
693/WS091	60" x 30" x 34"
693/WS092	72" x 30" x 34"
693/WS093	72" x 36" x 34"
<b>Laminated Hardwood Top</b>	
693/WS094	60" x 30" x 34"
693/WS095	72" x 30" x 34"
693/WS096	72" x 36" x 34"

**9 WORKBENCH WITH CABINET, UPPER SHELF AND ELEC. PANEL**



- 1 Top of Your Choice
- 1 Cabinet
- 1 Leg
- 2 Shelf Supports
- 1 Shelf
- 1 Back Stop

Stock Number	Dimensions W x D x H
<b>Steel Top</b>	
693/WS097	60" x 24" x 34"
693/WS098	60" x 30" x 34"
693/WS099	60" x 36" x 34"
693/WS100	72" x 24" x 34"
693/WS101	72" x 30" x 34"
693/WS102	72" x 36" x 34"
<b>Plastic Laminate Top</b>	
693/WS103	60" x 30" x 34"
693/WS104	72" x 30" x 34"
693/WS105	72" x 36" x 34"
<b>Laminated Hardwood Top</b>	
693/WS106	60" x 30" x 34"
693/WS107	72" x 30" x 34"
693/WS108	72" x 36" x 34"

SUPPLIER FOR THE THREE WORKBENCHES SHOWN ABOVE:



Rousseau work centre systems are specifically designed to offer a multitude of different layouts and accessories, making it easy to create the perfect workspace for your exact needs. This type of work centre is ideal for both industrial and commercial applications, as it is built to withstand the wear and tear of everyday use.

**10 HD WELDING TABLES**

Reference Number – EDW2274R



**▲ Built to suit and/or made to order.**

All HD welding tables come fully equipped with a 3/4" plate top and a 1" galvanized grate shelf for a strong, sturdy work centre you can rely on. This type of work centre is available in a selection of different dimensions and can easily be adjusted in height on 2" increments, making it easy to find the perfect solution for your workspace needs. HD welding tables are also available with 8" phenolic casters for easy transportation and maneuverability.

A
<b>SUBJECT A: HD Mobile Welding Table 36" x 72"</b>
3/4" plate top – uncoated
1" galvanized bar grate shelf – 20" from floor
Adjustable height – 32" to 36" on 2" increments
8" phenolic casters – 2 rigid, 2 swivel with brake
Powder coated standard red

B
<b>SUBJECT B: HD Mobile Work Table 47" x 95"</b>
3/4" plate top – corners radiused 4" – uncoated
1" galvanized bar grate shelf – 14" from floor
Adjustable height – 32" to 36" on 2" increments
8" phenolic casters – 2 rigid, 2 swivel with brake
Powder coated standard red

C
<b>SUBJECT C: HD Stationary Work Table 47" x 95"</b>
3/4" plate top – corners radiused 4" – uncoated
1" galvanized bar grate shelf – 14" from floor
Adjustable height – 32" to 36" on 2" increments
Powder coated standard red

**▲ This made to order item can be between \$5,000 - \$6,000.**

SUPPLIER:



**11 WALL MOUNTED SHOP DESK**

Stock Number – FI518



All wall mounted shop desks are specifically designed to provide a convenient writing area without utilizing any valuable floor space. This type of desk features a large 34 1/2" wide x 30" deep desk top, a 9" deep riser shelf, and an extra wide lockable drawer that runs on smooth full extension ball bearing drawer sliders. Wall mounted shop desks require minor assembly and can easily be mounted in most locations.

**12 FLOOR MODEL FOREMAN'S DESK**

Stock Number – FI519



All floor model foreman's desks come fully equipped with a 9" deep riser and a sloped writing top that is 43" high at the front. Floor model foreman's desks are 34 1/2" wide x 2" deep x 53" high, making it the ideal desk for most workspaces. This type of desk requires minor assembly.

**13 CABINET STYLE SHOP DESK**

Stock Number – FI520



Cabinet style shop desks are solid units that offer the same convenience as the floor model foreman's desk with the added bonus of a locking cabinet for extra storage space. This type of desk is 39 1/2" wide x 30" deep x 53" high and comes fully assembled. All cabinet style shop desks come fully equipped with a sloped writing top that is 43" high at the front and a large locking, double door cabinet.

## 1 SECURITY WIRE FENCING

- Ideal for the storage of expensive small parts in warehouse or factory
- Adapts to your needs
- Quick to set up
- Convenient to move or relocate
- Easy to install
- Please call for sales assistance.
- Shipped K.D.



Size (feet) W x D x H	2 Sides	3 Sides	4 Sides
	Stock Number	Stock Number	Stock Number
12 x 8 x 8	760/X2-1208	760/X3-1208	760/X4-1208
20 x 8 x 8	760/X2-2008	760/X3-2008	760/X4-2008
20 x 16 x 8	760/X2-2016	760/X3-2016	760/X4-2016
20 x 20 x 8	760/X2-2020	760/X3-2020	760/X4-2020
28 x 20 x 8	760/X2-2820	760/X3-2820	760/X4-2820

\*\*Above units come complete with 4'0" sliding door\*\*  
 \*\*Call our sales department for custom sizes and options\*\*  
 \*\*Readily available option available in blue only\*\*

SUPPLIER:



## 2 EZ RECT SECURITY LOCK-UPS

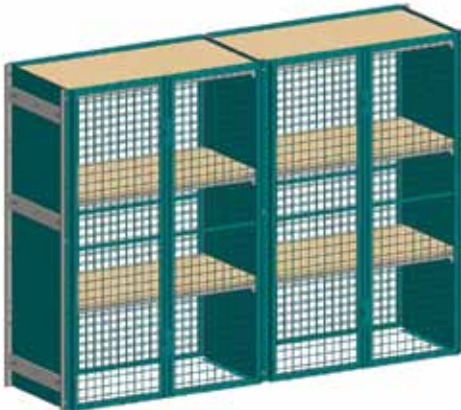

- Transforms your E-Z-Rect shelving into a lockable storage unit
- Bolt on to existing E-Z-Rect shelving without having to dismantle

- Lockable Wire Mesh Doors
- Wire Mesh Back Panel
- Solid Side Panels
- Easy to Install

PART NUMBER
<b>DOOR SETS:</b>
<b>760/WFL48-60:</b> Framed Lock Up Doors 49.5" x 60"
<b>760/WFL48-72:</b> Framed Lock Up Doors 49.5" x 72"
<b>760/WFL48-84:</b> Framed Lock Up Doors 49.5" x 84"
<b>760/WFL48-96:</b> Framed Lock Up Doors 49.5" x 96"
<b>760/WFL48-120:</b> Framed Lock Up Doors 49.5" x 120"
<b>760/WFL72-96:</b> Framed Lock Up Doors 73.5" x 96"
<b>760/WFL72-120:</b> Framed Lock Up Doors 73.5" x 120"

PART NUMBER
<b>BACK PANELS:</b>
<b>760/WMF48-60:</b> Wire Mesh Frame 48" x 60"H
<b>760/WMF48-72:</b> Wire Mesh Frame 48" x 72"H
<b>760/WMF48-84:</b> Wire Mesh Frame 48" x 84"H
<b>760/WMF48-96:</b> Wire Mesh Frame 48" x 96"H
<b>760/WMF48-120:</b> Wire Mesh Frame 48" x 120"H

PART NUMBER
<b>SIDE PANELS:</b>
<b>760/W72:</b> Solid Panel 23.75" x 60"
<b>760/W73:</b> Solid Panel 23.75" x 72"
<b>760/W74:</b> Solid Panel 23.75" x 84"
<b>760/W75:</b> Solid Panel 23.75" x 96"
<b>760/W76:</b> Solid Panel 23.75" x 120"

SUPPLIER:



1 MEZZANINES

Mezzanines are the ideal option for creating more storage and workspace in both commercial and industrial warehouses, as they offer a high level of strength and durability you can count on. This type of floor system comes complete with a powder-coat finish to help prevent rusting and to stand up to the wear and tear of everyday use.



SUPPLIER:  
**UNITRAN**  
 MANUFACTURERS LTD.  
 Made in Canada

MEZZANINE LADDERS

Easy-to-install ladders help prevent injuries by providing an easy, safer access to docks and mezzanines

Designed to be installed with the top tread level with the floor being served

For side step option, grab rungs continue for four feet above the top tread, for safety as per OSHA requirements

Steps are 18" wide by 1 1/4" deep by 1 1/2" high one-piece steel with self-cleaning, perforated, raised buttons for slip-resistant footing

Floor Mounts are available. Add-FM to model number and specify exact platform height

Designed to be mounted beside truck loading doors to provide safer access without obstructing the door opening

SUPPLIER:



Stock No.	Threads	Recommended Platform Height
LAD-W-02	2	2' 3" - 3' 3"
LAD-W-03	3	3' 3" - 4' 3"
LAD-W-04	4	4' 3" - 5' 3"
LAD-W-05	5	5' 3" - 6' 3"
LAD-W-06	6	6' 3" - 7' 3"
LAD-W-07	7	7' 3" - 8' 3"
LAD-W-08	8	8' 3" - 9' 3"
LAD-W-09	9	9' 3" - 10' 3"
LAD-W-10	10	10' 3" - 11' 3"
LAD-W-11	11	11' 3" - 12' 3"
LAD-W-12	12	12' 3" - 13' 3"
LAD-W-13	13	13' 3" - 14' 3"
LAD-W-14	14	14' 3" - 15' 3"
LAD-W-15	15	15' 3" - 16' 3"
LAD-W-16	16	16' 3" - 17' 3"



Stock No.	Threads	Total Rungs	Recommended Platform Height
LAD-S-02	2	6	2' 3" - 3' 3"
LAD-S-03	3	7	3' 3" - 4' 3"
LAD-S-04	4	8	4' 3" - 5' 3"
LAD-S-05	5	9	5' 3" - 6' 3"
LAD-S-06	6	10	6' 3" - 7' 3"
LAD-S-07	7	11	7' 3" - 8' 3"
LAD-S-08	8	12	8' 3" - 9' 3"
LAD-S-09	9	13	9' 3" - 10' 3"
LAD-S-10	10	14	10' 3" - 11' 3"
LAD-S-11	11	15	11' 3" - 12' 3"
LAD-S-12	12	16	12' 3" - 13' 3"
LAD-S-13	13	17	13' 3" - 14' 3"
LAD-S-14	14	18	14' 3" - 15' 3"
LAD-S-15	15	19	15' 3" - 16' 3"
LAD-S-16	16	20	16' 3" - 17' 3"

4 STAIRCASES

All staircases for mezzanine structures offer a 36" overall width, as well as stairs with a 7" rise, an 11" run, and an enclosed back. This type of mezzanine accessory also comes with a 36" high (above the tread nosing) handrail and 12" handrail extensions at the top and bottom of the stairs for added safety. Staircases for mezzanine structures come in a wide range of heights, treads, and runs, making it easy to find the perfect fit for your specific needs. All staircases ship knocked down for convenience.

- 36" overall width
- 7" rise with 11" run
- 36" high handrail above tread nosing
- enclosed back
- 12" handrail extension top and bottom of stairs
- Ships KD

SUPPLIER:



\*Note: Allowable deck height variance = 2% of stair run. Ex: SC119 with 16 treads and 177" run (177 x 2% = 3.54"). Deck height tolerance = 115.5" to 122.5"

Stock No.	Height	Treads	Run
760/SC028	28"	3	34"
760/SC035	35"	4	45"
760/SC042	42"	5	56"
760/SC049	49"	6	67"
760/SC056	56"	7	78"
760/SC063	63"	8	89"
760/SC070	70"	9	100"
760/SC077	77"	10	111"
760/SC084	84"	11	122"
760/SC091	91"	12	133"
760/SC098	98"	13	144"
760/SC105	105"	14	155"
760/SC112	112"	15	166"
760/SC119	119"	16	177"
760/SC126	126"	17	188"
760/SC133	133"	18	199"
760/SC140	140"	19	210"

## 5 PIVOT SAFETY GATES

SKU: G-PSG

Pivot Safety Gates are designed to protect open areas on mezzanines, storage platforms and rack systems during loading and unloading of material. Easy installation into existing handrail systems. When one side is raised, the other side is closed allowing for quick, convenient and safe access by forklifts and personnel.

- 5" Wide x 80" High Pivot Safety Gate
- Stock Code – 760/G-PSG8060
- 8" Wide x 80" High Pivot Safety Gate
- Stock Code – 760/G-PSG8096

SUPPLIER:



## 6 HANDRAIL SYSTEMS

At Unitran we manufacture a complete line of handrail systems and guardrail systems available through quick ship program. Our handrail system comes standard at 42"H with a top and centre rail and a 5 1/2" kick-plate.

SUPPLIER:



## 7 HANDRAIL SWING GATE

SKU: Handrail G12-5

Mezzanine Handrail Swing Gates are a great solution when you need the added security of a swing in gate while having adequate access to your mezzanine or storage platform. Designed for access area of 60". Compatible with Unitran guardrail systems, inquire for compatible options for other handrail systems.

SUPPLIER:



## 8 HANDRAIL DOUBLE SWING GATE

SKU: Handrail G13-5

Mezzanine handrail double swing gate is a great solution when you need added security of a swing in gate while having adequate access to your mezzanine or storage platform. Designed for access area of 96". Compatible with Unitran guardrail systems, inquire for compatible options for other handrail systems.

SUPPLIER:



## 9 HANDRAIL PIPE GATE

SKU: Handrail G9

Mezzanine handrail double swing gate is a great solution when you need added security of a swing in gate while having adequate access to your mezzanine or storage platform. Designed for access area of 96". Compatible with Unitran guardrail systems, inquire for compatible options for other handrail systems.

SUPPLIER:

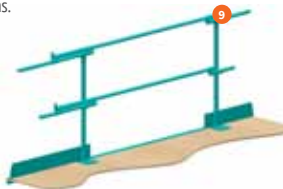

## 10 PIVOT CHAIN GATES

SKU: Handrail G6

Mezzanine Handrail Chain Gates are a great economical solution to provide an access point onto your mezzanine or storage platform. Designed for access area of 96" or less. Compatible with most guardrail systems.

SUPPLIER:

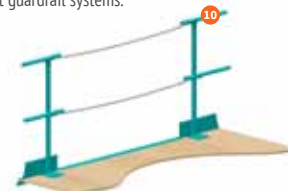

# PALLET TRUCKS AND LIFTING EQUIPMENT

## 1 DRUM LIFTER

Stock Number: 890/BC-1

- Drum lifter – Grips, Holds, and Moves drums in the upright position
- Attach to a forklift truck, crane or hoist
- Open or closed drums
- Tong-grip grips more tightly as force is applied
- Capacity - 1000 lbs.

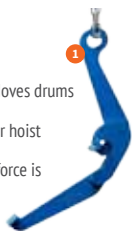

SUPPLIER:



## 2 FORKLIFT WORKSTAGE

Stock Number: 890/510

- Attaches to your forklift
- All welded construction
- 42" high safety rail
- Latching front gate
- 5" high kick-plate
- 42" deep x 36" wide platform
- Non-slip steel deck
- 2 3/4" x 7 3/4" full length fork pockets
- Overall height = 75"
- Inside height = 72"
- Safety chains to secure to forklift
- Safety mesh back to prevent items being caught on forklift
- Conforms to ANSI/ASME B56.1 Safety Standards
- Powder coat finish
- Capacity - 500 lbs.



SUPPLIER:



## 3 LIFTRITE TITAN PALLET TRUCKS



- New one-piece pump for improved performance and reliability
- Includes ergonomic handles and articulating steering wheels
- 3" fork lowered height, 7 3/4" fork raised height
- 2 Year Limited Warranties on LR models
- 7" fork width

Stock Number	Fork Dimensions W X L (inches)	Capacity Lbs.
510/LR-27A	27" x 48"	5500
510/LR-27B	27" x 42"	5500
510/LR-27C	27" x 36"	5500
510/LR-20A	20 1/2" x 48"	5500
510/LR-20B	20 1/2" x 42"	5500
510/LR-20C	20 1/2" x 36"	5500
510/PT-ECONO	27" x 48"	5000
*510/C51HLY	27" x 60"	5500
*510/C52JLY	20 1/2" x 72"	5500
*510/C51JLY	27" x 72"	5500
*510/C51LLY	27" x 96"	5500
*510/L5B3LY	16" x 36"	5500

## MOBILE LIFT TABLES

- ### 4 Standard Dandy Lift
- The Dandy Lift offers the ideal solution to reliable, economic lifting over years of service
  - Pivot points have hardened pins in lifetime lubrication bearings
  - Simple grouped controls make tables easy to operate
  - Hard chrome-plated pistons and rods resist rust and corrosion for dependability and long life
  - Honed heavy-walled cylinders improve both seal performance and durability



- ### 5 Low Profile Dandy Lift
- Ideal for use in factories, warehouses and repair shops
  - Fully lowered height of only 3 1/8"
  - Platform fits easily under most skids and wire baskets
  - Comes with 2 rigid and 2 swivel rubber casters
  - Floor lock break is standard
  - Ability to lift loads of 1100 lbs.
  - Lift height: 29 1/2"



Stock Number	Cap. Lbs.	Platform Lowered vs. Raised	Platform W x L (inches)	Overall W x L (inches)
MA431	330	8 3/10" x 29"	17 7/10 x 28	17 7/10 x 37 7/10
MA432	550	9 1/2" x 31 4/5"	19 7/10 x 31 1/2	19 7/10 x 38 1/5
MA421	770	13 3/5" x 49 4/5"	23 3/5 x 35 4/5	23 3/5 x 42 1/10
MA422	1100	11 4/5" x 36 3/5"	23 3/5 x 35 4/5	23 3/5 x 42 1/10
MA423	1760	13" x 40 1/5"	23 3/5 x 39 2/5	23 3/5 x 45 9/10
MA464	1100	3" x 29 1/2"	19 7/10 x 37 1/10	19 7/10 x 55 2/5

## 6 PALLETPAL 360 SPRING LEVEL LOADER

- PalletPal 360 Fully Automatic Spring-Actuated
- Capacity - 220 lbs - 4500 lbs
- Turntable Diameter - 43 5/8"
- Lowered Height - 9 1/2"
- Vertical Travel - 18 1/2"
- Raised Height - 28"



## 7 PREMIUM PALLET JACK



- Premium Blue Label (BS Series) Pallet Jacks
- Easy operation and full control by operator at all times
- Exceptional maneuverability in tight quarters
- Greater flexibility of operation
- Products can take the hard use of a rough industrial environment

- Easier steering and smooth operation
- Years of trouble-free use
- Ease of maintenance
- Fully rebuildable

Stock Number	Cap. Lbs.	Overall Fork Dimensions		Fork Height	
		Length	Width	Lowered	Raised
070/BS-20A	5500	48"	20.5"	2.9"	7.8"
070/BS-20B	5500	42"	20.5"	2.9"	7.8"
070/BS-20C	5500	36"	20.5"	2.9"	7.8"
070/BS-27A	5500	48"	27"	2.9"	7.8"
070/BS-27B	5500	42"	27"	2.9"	7.8"
070/BS-27C	5500	36"	27"	2.9"	7.8"

## 1 PALLET PULLER

Stock Number: 890/PP-100

- Pulls loaded pallets to the edge of a dock or truck
- Bites into wood
- Positive grip on wood pallets
- Extends reach of fork trucks
- Saves time
- Capacity = 1000 LBS

SUPPLIER:



## 2 DOCK BOARDS

• For Forklift and Heavy-Duty Applications!



## 3 DOCK PLATES

• For Light-Duty Applications!  
Not for Forklift Use.



## 4 RUBBER WHEEL CHOCK

Stock Number: 500/WHC-XMR



- Size: 6 1/2" W x 8 1/2" H x 9 1/2" D
- Weight: 10 lbs
- Comes with Steel Ring to attach chain.

## 5 DOCK LADDERS



- Powder-coated standard "Unitran Safety Blue"
- Side-Step models are designed to be installed with the top tread level with the floor being served. Grab rungs continue for four feet above the top tread, for safety as per OSHA requirements. They are designed to be mounted beside truck loading doors to provide safer access without obstructing the door opening.
- Walk-Through models have the top tread flush with dock or mezzanine floor, for safety, as per OSHA requirements. Projection from wall is 6" clear.

- Floor Mounts are available. Add FM to model number and specify exact mezzanine height.

- Grip-Tread steps are 18" wide by 1 1/4" deep by 1 1/2" high one-piece steel with self-cleaning, perforated, raised buttons for slip-resistant footing.

SUPPLIER:



Size (W x L)	Height Differential	Stock Number
<b>8,000 lbs. Capacity</b>		
54" x 36"	5"	KH177
54" x 48"	7"	KH178
54" x 60"	9"	KH179
60" x 36"	5"	KH181
60" x 48"	7"	KH182
60" x 60"	9"	KH183
60" x 72"	11"	KH184
<b>10,000 lbs. Capacity</b>		
54" x 36"	5"	KH105
54" x 48"	7"	KH106
54" x 60"	9"	KH107
60" x 36"	5"	KH119
60" x 48"	7"	KH120
60" x 60"	9"	KH109
60" x 72"	11"	KH110
72" x 48"	7"	KH115
72" x 60"	9"	KH116
72" x 72"	11"	KH117
<b>14,000 lbs. Capacity</b>		
60" x 36"	5"	KH126
60" x 48"	7"	KH127
60" x 60"	9"	KH128
60" x 72"	11"	KH129
72" x 36"	5"	KH134
72" x 48"	7"	KH135
72" x 60"	9"	KH136
72" x 72"	11"	KH137
<b>Extras</b>		
Forklift Handles		KH191
Adjustable Spanlocks		KH190
Fixed Spanlocks		KH192

Size W x L	Height Diff.	3/8" Thick Plate Regular Duty		1/2" Thick Plate Heavy Duty	
		Stock No.	Cap. Lbs.	Stock No.	Cap. Lbs.
36" x 48"	7"	KH148	1,700	-	-
42" x 48"	7"	KH153	2,000	-	-
48" x 36"	5"	KH156	3,000	KH195	5,400
48" x 42"	6"	KH157	2,600	KH196	4,600
48" x 48"	7"	KH158	2,250	KH197	4,000
48" x 60"	9"	KH159	1,500	KH198	2,700
48" x 72"	11"	KH160	1,100	KH199	2,000
60" x 36"	5"	KH171	3,750	KH201	6,700
60" x 48"	7"	KH172	2,800	KH202	5,000

### HELPFUL INFO

How To Select Your Dock Board or Dock Plate, 4 Simple Steps!

#### Step 1.

Capacity. Take 80% of the combined weight of lift truck and maximum load

#### Step 2.

Width. Add 12" to width of widest vehicle. Most popular is 60"

#### Step 3.

Height Differential. Determine average vertical distance between truck bed and dock. (Trucks can be higher or lower than dock)

#### Step 4.

Relate these measurements to the table below and choose board closest to your requirements.

## 6 DOCK BUMPERS

- Helps prevent damage to dock, building, trucks and cargo
- Absorbs over 80% of truck impact

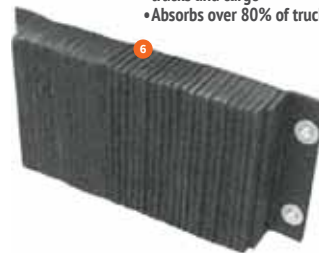

Stock Number	Mount	Size H x W x D
500/H1410	Horizontal	10" x 14" x 4"
500/H3610	Horizontal	10" x 36" x 4"
500/V1120	Vertical	20" x 11" x 4"

**7 DOME MIRRORS**



- Increase surveillance and prevent accidents due to blind corners
- Constructed of acrylic for added durability
- All mirrors have a black protective edge and hanging clips
- Full dome mirrors come with hanging chains and hooks
- All mirrors are open-topped

**Ideal Locations:**

- 360° 4 Way Intersections
- 180° "T" Intersections
- 90° Corner Intersections

	7 Full Dome 360°	8 Half Dome 180°	9 Quarter Dome 90°
Mirror Diameter	Stock Number	Stock Number	Stock Number
20"	SEJ875	SEJ879	SEJ883
24"	SEJ876	SEJ880	SEJ884
31"	SEJ877	SEJ881	
47"	SEJ878	SEJ882	

**10 FORK EXTENSIONS**

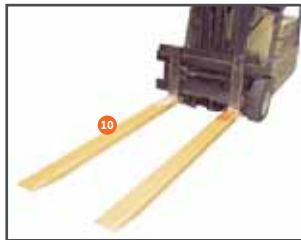

- Handle large and odd shaped loads with increased stability and minimum damage
- Available in 4", 5", 6" fork widths, lengths are from 54" to 96"
- Easy to use slide-on design
- Fork fits up to 2" thick
- Convenient on/off design
- Locking bar keeps extensions in place
- Fork extensions not to exceed 50% more than existing fork
- Wall Brackets available, ML282

Stock Number	Accommodates Fork Widths	Fork Extension Overall Width	Length	Max. Fork Thickness
MF775	4"	5"	54"	2"
MF776	4"	5"	63"	2"
ML346	4"	5"	72"	2"
MF778	4"	5"	84"	2"
ML348	4"	5"	96"	2"
MF781	5"	6"	54"	2"
MF782	5"	6"	63"	2"
ML347	5"	6"	72"	2"
MF784	5"	6"	84"	2"
MF785	5"	6"	96"	2"
MF787	6"	7"	54"	2 1/2"
MF788	6"	7"	63"	2 1/2"
MF789	6"	7"	72"	2 1/2"
MF790	6"	7"	84"	2 1/2"
MF791	6"	7"	96"	2 1/2"

**13 STRIP CURTAIN**



Strip curtains can be easily cut, punched, and mounted to any door or opening. All strip curtains are available in a selection of bulk roll and cut-to-length sizes, making it easy to find the perfect solution for your warehouse needs. Available in bulk rolls or cut to length.

Bulk Rolls:

\*\*Indicate length of "cut to length" strips upon ordering\*\*

Model No. Standard	Model No. Low Temp.	Size
715/SD8BK	715/SD8BKUS	8" x 0.08" x 300'
715/SD12BK	715/SD12BKUS	12" x 0.12" x 200'
715/SD16BK	715/SD16BKUS	16" x 0.16" x 100'

Cut to Length:

Model No. Standard	Model No. Low Temp.	Size
715/SD8CT	715/SD8CTUS	8" x 0.08"
715/SD12CT	715/SD12CTUS	12" x 0.12"
715/SD16CT	715/SD16CTUS	16" x 0.16"

**11 CONVEX MIRRORS**



Mirror Diameter	Indoor Stock Number	Outdoor Stock Number
12"	SDP505	SDP500
18"	SDP506	SDP501
26"	SDP507	SDP502
30"	SDP508	SDP503
36"	SDP509	SDP504

- Removed blind spots reducing the chance of accidents caused by blind corners
- Includes adjustable arm
- Adjustable ball and swivel mount with 100° viewing angle

•NOTE: Dome mirrors available under "Dome Mirrors"

**12 STRIP CURTAIN DOORS**



Strip curtain doors come complete with PVC strips and universal hardware for easily mounting the strip curtain. All strip curtain doors are available in standard and low temperature options (low temperature is only recommended for interior uses for temperatures -40C to 37C) and come in a selection of different dimensions (4' x 7" to 12' x 12"). Strip curtain doors can also be easily trimmed down in order to be custom fitted to almost any door opening.

**Ordering Information**

Every strip curtain door comes complete with PVC strips and universal hardware for mounting strip curtain. Simple-to-flow installation instructions are included in every package.

1. Determine inside width and height of door opening
2. Select type of PVC material required, STANDARD or LOW TEMP - Low Temp, recommended for interior use only for temperatures from -40C to 37C
3. Select from the standard sizes listed in the chart below - If required size is not available, order the next largest size - Installation instructions describe how simple trimming can custom fit almost any door opening
4. Special size doors and hanging applications are available upon request
5. For overhead doors, please call one of our sales representatives for assistance

**Standard Door Size:**

Model No. Standard	Model No. Low Temp.	Strip Size	Door Opening W x H (feet)
KF022	KF004	8" (8" x 0.08") **Doors with 8" strips have 2" standard overlap**	4 x 7
KF023	KF005		5 x 8
KF024	KF00		6 x 8
KF026	KF00	12" (12" x 0.012") **Doors with 12" strips have 4" standard overlap**	8 x 8
KF025	KF00		8 x 10
KF020	KF00		10 x 10
KF021	KF00		12 x 12

**Replacement Strips - 5 Per**

Model No. Standard	Model No. Low Temp.	Strip Size
KF032	KF013	(8" x 0.08) x 8'
KF029	KF011	(12" x 0.012) x 12'

## 1 DIAMOND-PLATE



- Our Diamond Plate products define the market for dry area anti-fatigue matting
- These mats have a Nitricell® sponge base, a unique & resilient nitrile rubber composite that provides unparalleled comfort, resilience and long-term performance
- Designed for optimised worker productivity in heavy-use production and lab areas, the PVC diamond-plate surface resists abrasion and most chemical spills
- Edges safety bevelled

### UltraSoft Diamond-Plate No. 414

Ultimate Performance has a double thick Nitricell® sponge base, 15/16" for a little extra comfort!

No. 414		
StockNumber		Dimensions W' x L'
Black/Yellow	Black/Black	
SAJ810	SAJ809	2 x 3
NG924	NG917	3 x 5

### Diamond-Plate SpongeCote No. 415

Best Performance is a standard 9/16" thick and has been a best seller for over 20 years!

No. 415		
StockNumber		Dimensions W' x L'
Black/Yellow	Black/Black	
NB416	NB420	2 x 3
NB430	NB431	3 x 5

\*\*Custom sizes available up to 4' x 75"

## 2 ULTRA-TRED ARMORCOTE



- Urethane coating gives this anti-fatigue mat extra durability
- PVC sponge with a urethane wear-layer for longer performance
- The double-thick urethane coating offers more abrasion and chemical resistance than comparable sponge products
- A tremendously versatile, yet affordable mat
- Ultra Tred is ideal for use in mostly dry applications such as labs and other medium traffic areas
- 3/8" thick with eye catching yellow safety borders
- Colour: Black with Yellow Borders

StockNumber	Dimensions W' x L'
NB533	2 x 3
NB537	3 x 5
NB534	3 x 12
SAJ811	2 x 60
NB538	3 x 60
NB540	4 x 60

\*\*Custom sizes available up to 4' x 60"

## 3 STANDARD CORRUGATED VINYL

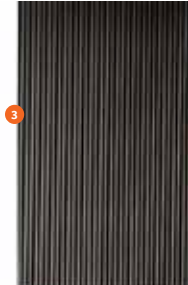

- Protects floors from foot traffic or special events
- Adds traction where needed
- Reduces cleaning costs
- Flexible, yet durable vinyl compound easily rolls up after use and is resistant to many chemicals and cleaning fluids
- 1/8" thick
- Colour: Black

StockNumber	Dimensions W' x L'
SDL875	2 x 75
SDL876	3 x 75
SDL877	4 x 75
SDL878	2 x lin. ft.
SDL879	3 x lin. ft.
SDL880	4 x lin. ft.

## 4 DRAINAGE MATS

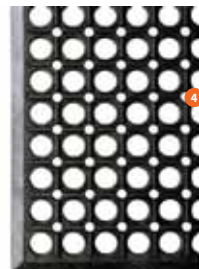

- Perfect for wet commercial or industrial areas
- General purpose, natural rubber compound for use around water and non-caustic agents
- Lightweight design eases the strain of cleaning, yet keeps employees comfortable
- Functional drainage design
- Moulded bevelled edges for easy access
- Colour: Black

Stock Number	Dimensions W' x L'	Thickness	Design
SDM621	3 x 5	1/2"	Standard
SDM618	3 x 10	1/2"	Standard
SDM619	3 x 20	1/2"	Standard
SFQ525	3 x 5	7/8"	Standard
NB632	3 x 5	1/2"	Light-Weight
NB630	3 x 10	1/2"	Light-Weight
NB631	3 x 20	1/2"	Light-Weight

## 5 TUF SPONGE



- For use in all dry work areas
- Blow-n-PVC sponge design to reduce floor hardness up to 50%
- Available in workstation mats and rolls, they can easily be "custom" cut to fit your work areas
- Available in widths up to 60" with all edges safely rounded on full rolls and stock sizes

Stock Number	Dimensions W' x L'	Thickness	Colour
NB550	2 x 3	3/8"	Black
NB551	2 x 3	3/8"	Grey
NB565	3 x 5	3/8"	Black
NB566	3 x 5	3/8"	Grey
NB568	3 x 60	3/8"	Light-Weight
Black	3 x 10	1/2"	Light-Weight
NB569	3 x 60	3/8"	Grey
SAL174	2 x 3	5/8"	Black
SAL180	3 x 5	5/8"	Black

# OUR CORE VALUES



**Treat** others as you would like to be treated



**Under** promise & over deliver



**Be** accountable and take responsibility



**Celebrate** successes



**Be** passionate and determined



**Remain** on the learning curve



**Focus** on our customer



**Enjoy** your work

# COMMANDER WAREHOUSE EQUIPMENT LTD.

